

LEGEND

- EXISTING CONTOURS
- PROPOSED CONTOURS
- PROPOSED SPOT ELEVATION
- TREE TO BE REMOVED
- L.O.S. = LINE OF SIGHT
- (E) = EXISTING
- (N) = NEW, OR PROPOSED
- EP = EDGE OF PAVEMENT
- = CULVERT: 18" CORRUGATED PVC WITH SMOOTH INTERIOR L = 135'; S = 4.37%

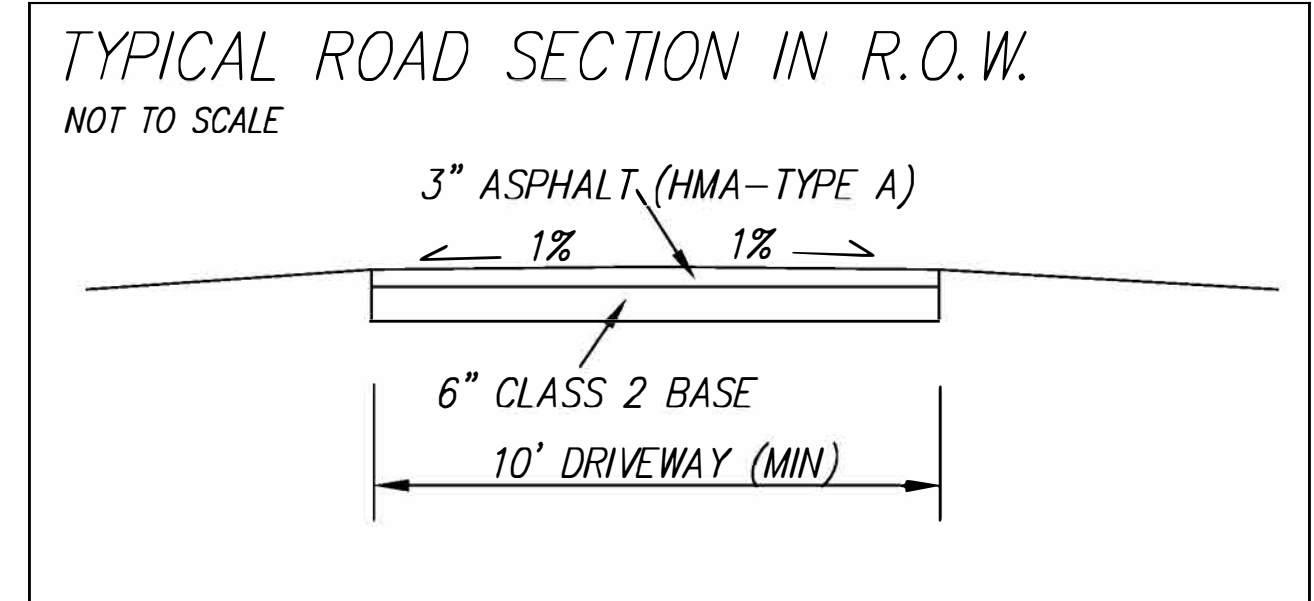

EARTHWORK NOTES

CUT VOLUME IN CALTRANS R.O.W.: 1209 CY
 CUT VOLUME ON PRIVATE PROPERTY: 1976 CY
 TOTAL CUT VOLUME : 3185 CY
 TOTAL OFF-HAUL VOLUME (WITH 1.2 EXPANSION FACTOR): 3822 CY

NO FILL

LENGTH OF IMPROVED ROAD IN R.O.W. = 90 FT (ON C/L)
 WIDTH OF NEW DRIVEWAY = 10 FT MIN
 AREA OF DRIVEWAY IN R.O.W. = 1765 SF
 VOLUME OF CLASS 2 AGGRAGATE ROAD BASE (AB) = 35 CY
 ROAD SHALL BE PAVED BETWEEN HIGHWAY 84 EDGE OF PAVEMENT AND PROPERTY LINE.

DRAINAGE NOTES

1. INSTALL 18" DIAMETER CULVERT AS SHOWN.
2. EXISTING DRAINAGE PATTERNS IN R.O.W. SHALL NOT BE ALTERED.

PURPOSE OF WORK

BUILD NEW DRIVEWAY BY ADDING BASE ROCK AND ASPHALT, AND PERFORMING 3185 CUBIC YARDS OF GRADING (ALL EXCAVATION). PURPOSE OF NEW DRIVEWAY IS TO IMPROVE LINE OF SIGHT.

GENERAL NOTES

1. PLANS PREPARED AT THE REQUEST OF: ARANCHA CASAL, OWNER
2. SURVEY AND TOPOGRAPHY BY B&H SURVEYING, JANUARY 2020.
3. ELEVATION DATUM IS ASSUMED.
4. THIS IS NOT A BOUNDARY SURVEY.
5. HIGHWAY 84 SPEED LIMIT = 40 MPH: MINIMUM REQUIRED CORNER SIGHT DISTANCE = 300', BASED ON APPROVAL BY CALTRANS.
6. ANY OBLITERATED TRAFFIC STRIPES IN THE PROJECT VICINITY SHALL BE REPLACED IN KIND.
7. THERE ARE NO BUILDINGS ON THE PROPERTY AND NONE ARE PLANNED.

Sigma Prime Geosciences, Inc.
 SIGMA PRIME GEOSCIENCES, INC.
 332 PRINCETON AVENUE
 BAY, CA 94019
 TEL: 726-2880
 FAX: 726-3665

DATE: 7-28-20	DRAWN BY: CMK	CHECKED BY: AZG	REV. DATE:	REV. DATE:	REV. DATE:
---------------	---------------	-----------------	------------	------------	------------

ROAD PLAN
 CASAL PROPERTY
 LA HONDA ROAD (HWY 84)
 WOODSIDE, CALIFORNIA
 (APN 178-190-200)
 POST MILE 10.83

SHEET
 C-1



TRAFFIC CONTROL NOTES

1. INGRESS/EGRESS FOR CONSTRUCTION IS AT EXISTING PAVED DRIVEWAY TO THE NORTH, AS SHOWN. LINE OF SIGHT IS VERY POOR: FLAGGERS REQUIRED TO CONTROL TRAFFIC WHEN CONSTRUCTION EQUIPMENT IS ENTERING OR LEAVING SITE.
2. POSTED SPEED LIMIT AT PROJECT SITE IS 40 MPH.
3. CONTRACTOR SHALL INSTALL TRAFFIC CONTROL DEVICES PRIOR TO COMMENCEMENT OF CONSTRUCTION. CONTRACTOR SHALL ALSO MAINTAIN ALL TRAFFIC CONTROL DEVICES DURING CONSTRUCTION.
4. ACTUAL SIGN INSTALLATION LOCATIONS ARE TO BE DETERMINED IN THE FIELD. ALL SIGNS SHALL BE INSTALLED PER CALTRANS STANDARD PLAN RS1-RS4. SIGN LOCATIONS SHALL BE APPROVED BY THE COUNTY ENGINEER/INSPECTOR PRIOR TO ANY SHOULDER WORK.
5. SIGNS SHALL BE INSTALLED AND REMOVED BY THE CONTRACTOR IN ACCORDANCE WITH THESE PLANS AND AS DIRECTED BY THE COUNTY.
6. TRAFFIC CONTROL SIGNS SHALL NOT BLOCK DRIVEWAYS AT ANY TIME.
7. ALL TRAFFIC CONTROL DEVICES (SIGNS, CHANNELIZERS, ETC.) SHALL BE RETROREFLECTIVE AND/OR ILLUMINATED DURING NIGHTTIME TRAFFIC CONTROL.
8. THE PARKING OF ANY CONSTRUCTION-RELATED VEHICLES OR STORAGE OF ANY MATERIAL IS NOT ALLOWED ON A PUBLIC STREET.
9. ANY TRAFFIC STRIPING, PAVEMENT MARKINGS, PAVEMENT SURFACE, ETC. DAMAGED OR DESTROYED BY CONTRACTOR'S WORK SHALL BE REPLACED BY CONTRACTOR TO THE SATISFACTION OF THE CITY ENGINEER AT THE CONTRACTOR'S SOLE EXPENSE.
10. THE CONTRACTOR SHALL DETERMINE ULTIMATE PROJECT PHASING, ACTUAL DURATION OF EACH PHASE, AND SHALL COMMUNICATE SUCH CONSTRUCTION OPERATIONS TO THE COUNTY PUBLIC WORKS INSPECTOR.

Sigma Prime Geosciences, Inc.
 SIGMA PRIME GEOSCIENCES, INC.
 332 PRINCETON AVENUE
 HALF MOON BAY, CA 94019
 (650) 726-3590
 FAX 726-3593

DATE: 7-28-20	DRAWN BY: CMK	CHECKED BY: AZG
		REV. DATE:
		REV. DATE:
		REV. DATE:

TRAFFIC CONTROL PLAN
 CASAL PROPERTY
 LA HONDA ROAD (HWY 84)
 WOODSIDE, CALIFORNIA
 (APN 178-190-200)
 POST MILE 10.83

SHEET
 C-2

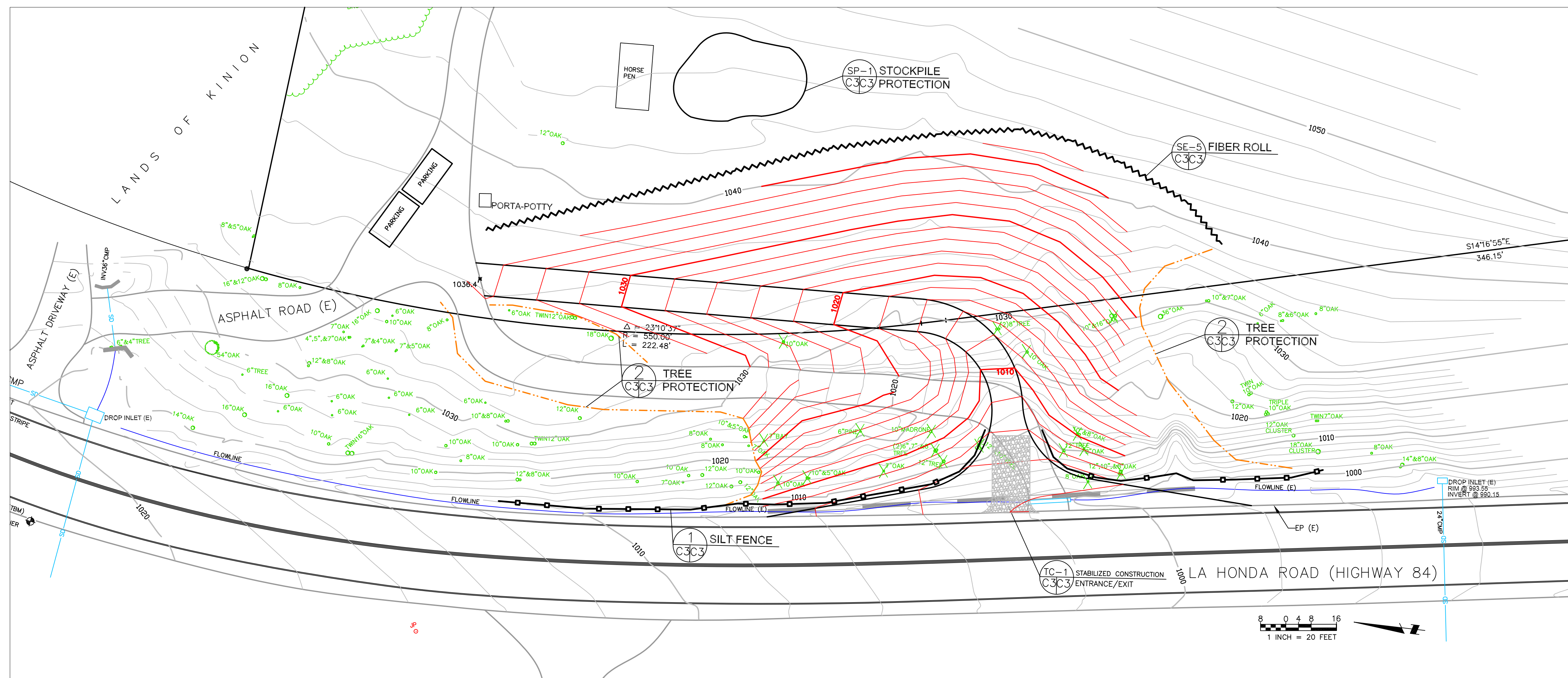

GENERAL EROSION AND SEDIMENT CONTROL NOTES

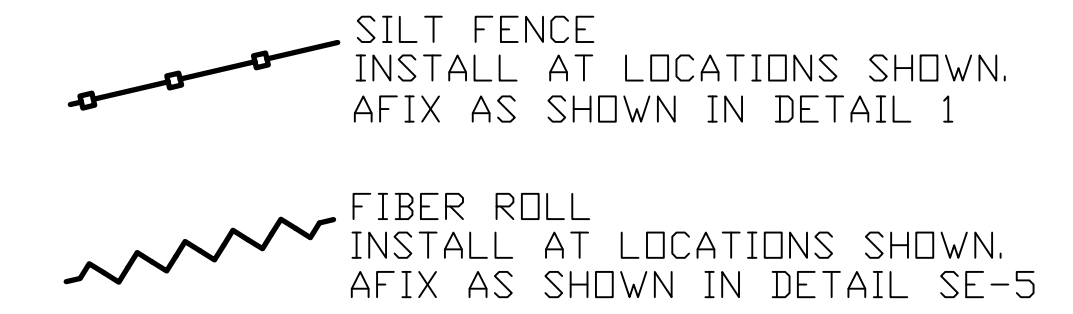

- Stockpiling of soil shall be as per detail SP-1.
- Perform clearing and earth-moving activities only during dry weather. Measures to ensure adequate erosion and sediment control shall be installed prior to earth-moving activities and construction.
- Erosion control materials to be on-site during off-season.
- Measures to ensure adequate erosion and sediment control are required year-round. Stabilize all denuded areas and maintain erosion control measures continuously between October 1 and April 30.
- Store, handle, and dispose of construction materials and wastes properly, so as to prevent their contact with stormwater.
- Control and prevent the discharge of all potential pollutants, including pavement cutting wastes, paints, concrete, petroleum products, wash water or sediments, and non-stormwater discharges to storm drains and watercourses.
- Avoid cleaning, fueling, or maintaining vehicles on-site, except in a designated area where wash water is contained and treated.
- Limit and time applications of pesticides and fertilizers to prevent polluted runoff.
- Limit construction access routes to stabilized, designated access points
- Avoid tracking dirt or other materials off-site; clean off-site paved areas and sidewalks using dry sweeping methods.
- Train and provide instruction to all employees and subcontractors regarding the Watershed Protection Maintenance Standards and construction Best Management Practices.
- Placement of erosion materials is required on weekends and during rain events.
- The areas delineated on the plans for parking, grubbing, storage etc., shall not be enlarged or "run over."
- Dust control is required year-round.
- Erosion control materials shall be stored on-site.

TREE PROTECTION NOTES

1. TREE PROTECTION FENCING SHALL BE INSTALLED PRIOR TO ANY GRADING AND REMAIN ON-SITE THROUGHOUT CONSTRUCTION PROCESS.
2. TREE PROTECTION FENCES SHALL BE INSTALLED AS CLOSE TO DRIP LINES AS POSSIBLE.
3. OWNER/BUILDER SHALL MAINTAIN TREE PROTECTION ZONES FREE OF EQUIPMENT AND MATERIALS STORAGE AND SHALL NOT CLEAN ANY EQUIPMENT WITHIN THESE AREAS.
4. ANY LARGE ROOTS THAT NEED TO BE CUT SHALL BE INSPECTED BY A CERTIFIED ARBORIST OR REGISTERED FORESTER PRIOR TO CUTTING, AND MONITORED AND DOCUMENTED.
5. ROOTS TO BE CUT SHALL BE SEVERED WITH A SAW OR TOPPER.
6. PRE-CONSTRUCTION SITE INSPECTION WILL BE REQUIRED PRIOR TO ISSUANCE OF BUILDING PERMIT.

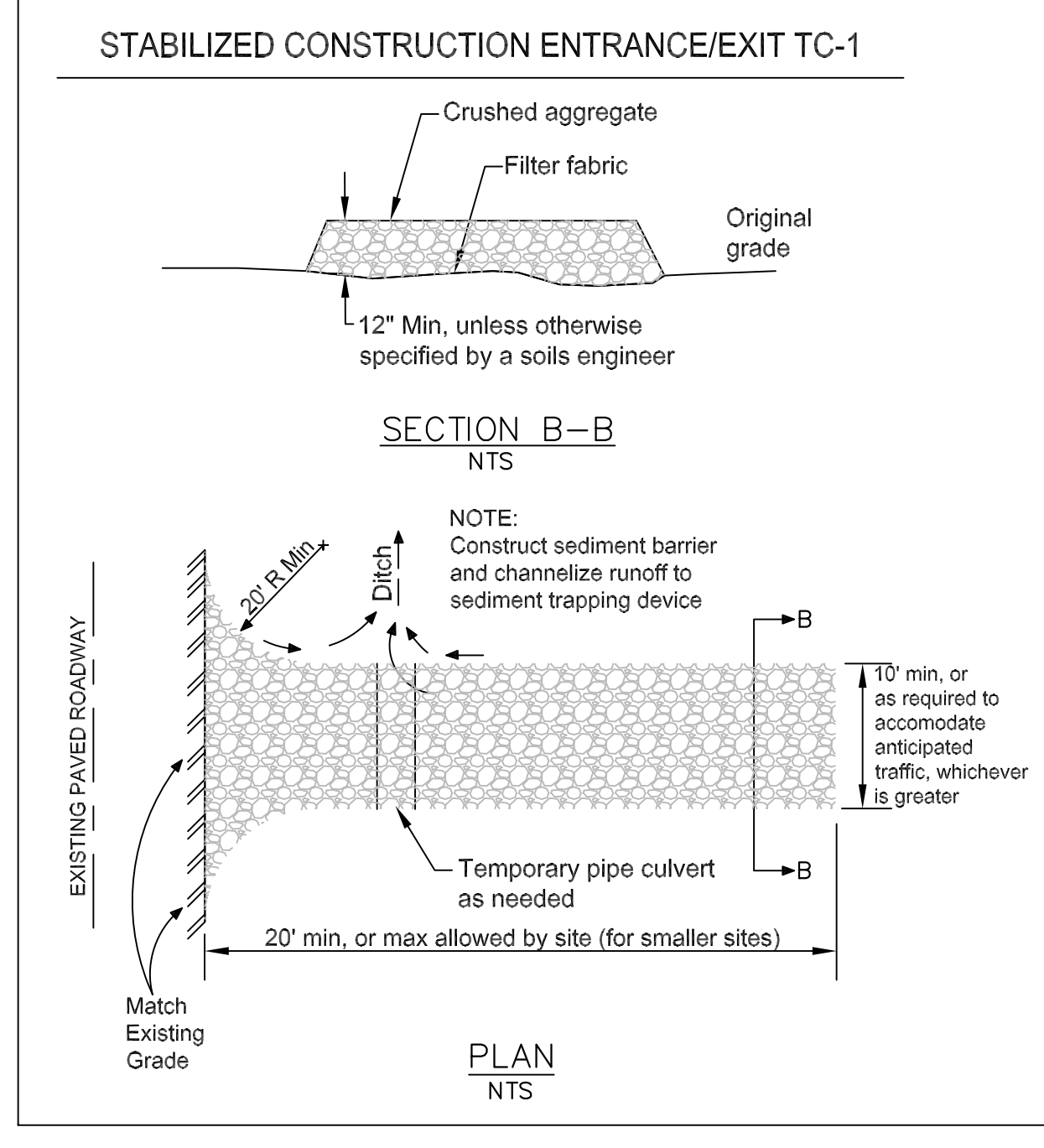
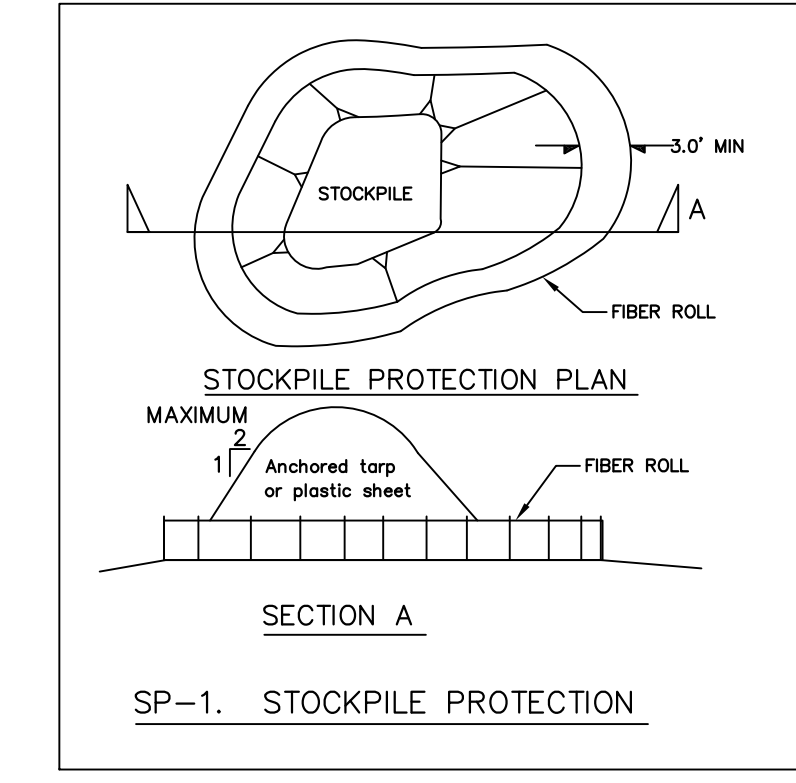
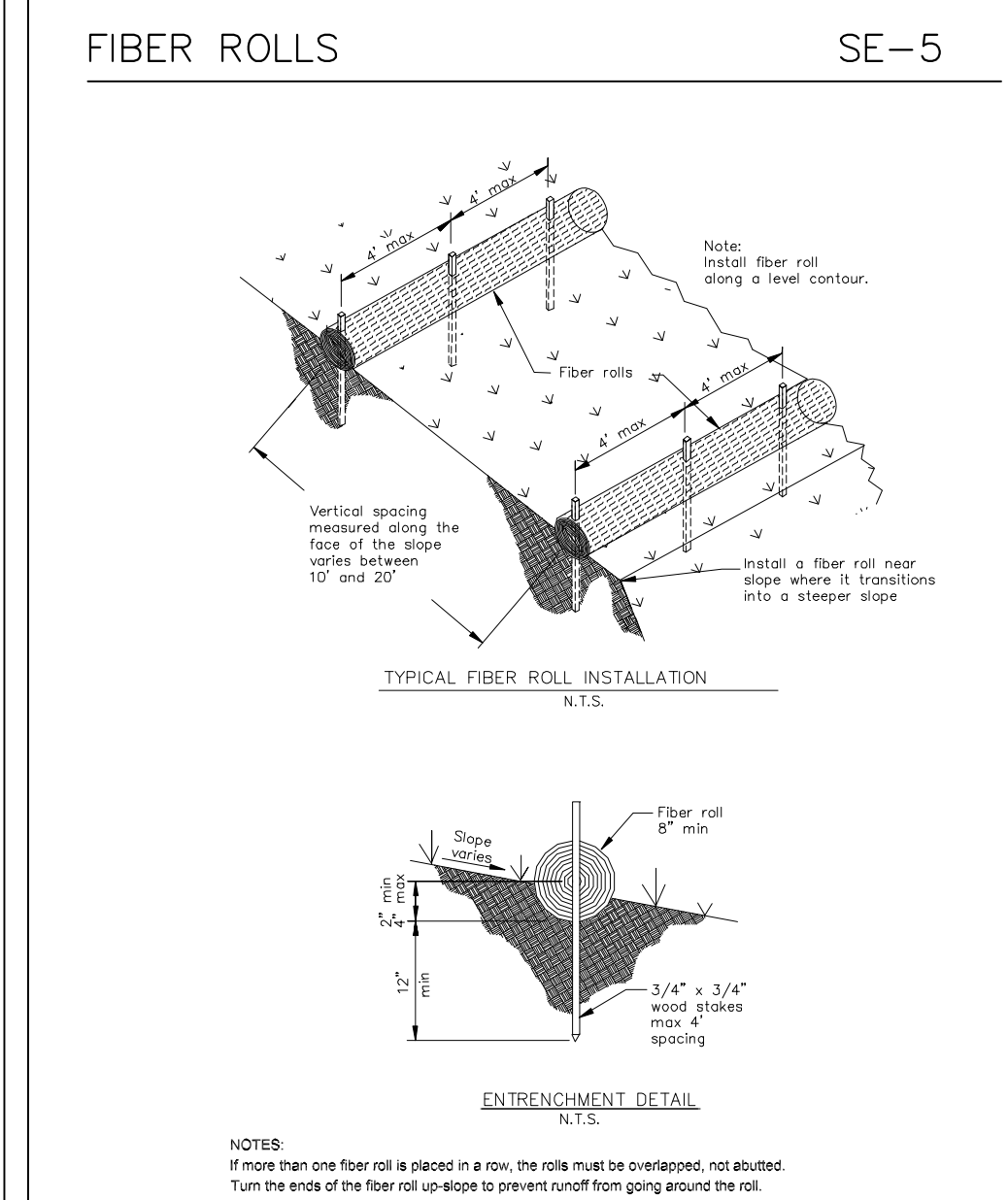
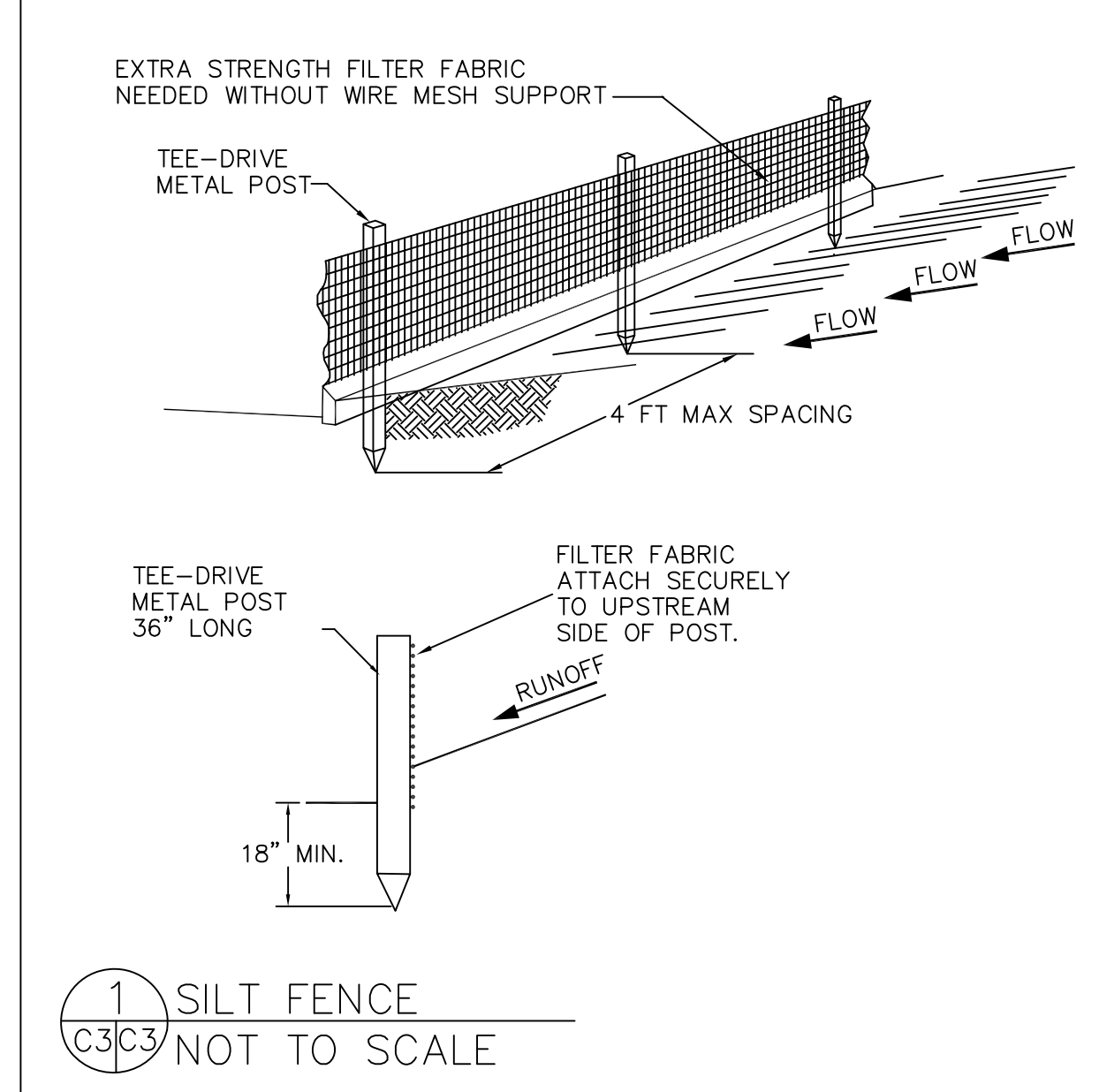
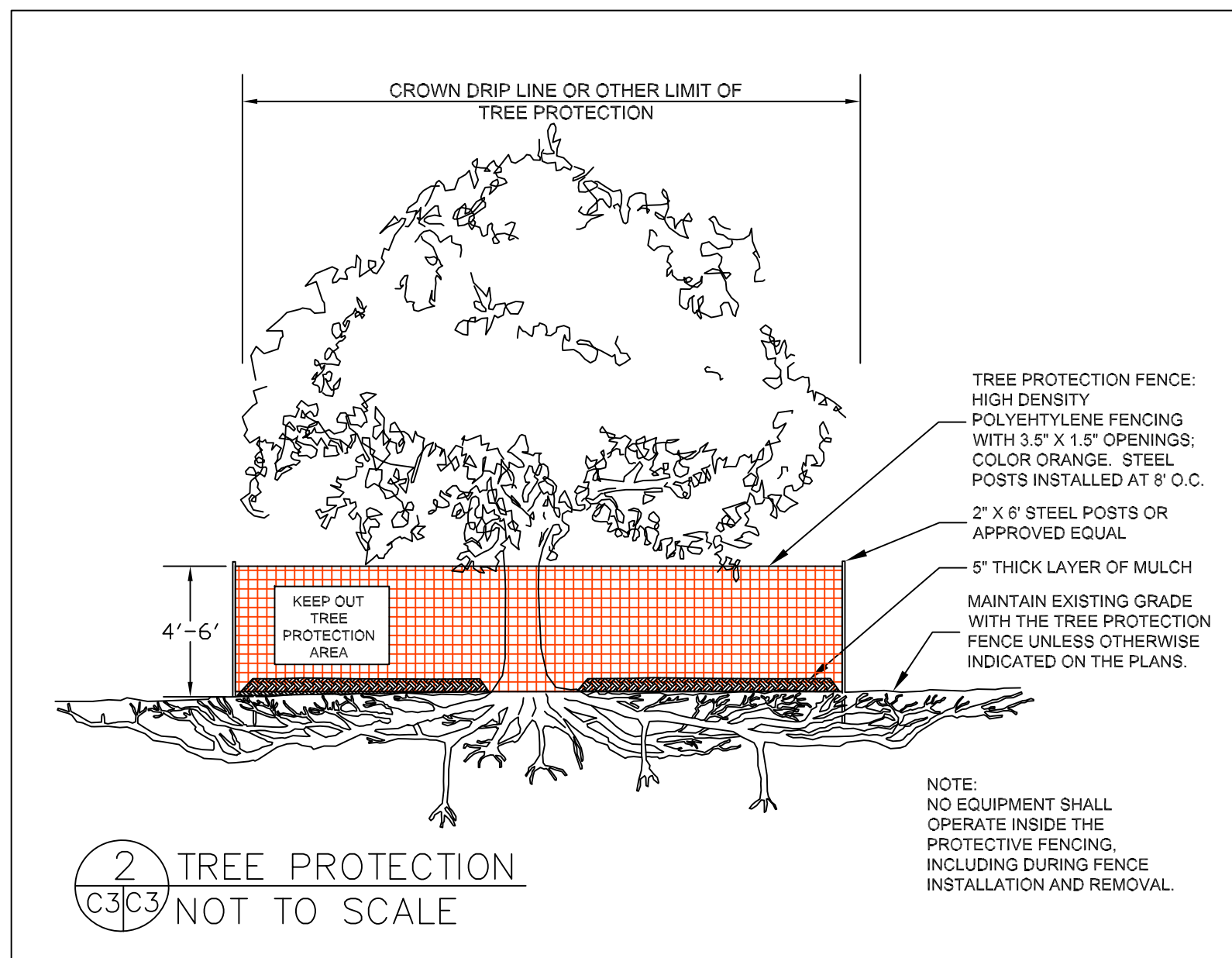

EROSION CONTROL POINT OF CONTACT

THIS PERSON WILL BE RESPONSIBLE FOR EROSION CONTROL AT THE SITE AND WILL BE THE COUNTY'S MAIN POINT OF CONTACT IF CORRECTIONS ARE REQUIRED.

NAME: ARANCHA CASAL
 TITLE/QUALIFICATION: OWNER
 PHONE: 650-206-0804
 PHONE:
 E-MAIL: ARANCHA@MAC.COM

EROSION AND SEDIMENT CONTROL PLAN

CASAL PROPERTY
 LA HONDA ROAD (HWY 84)
 WOODSIDE, CALIFORNIA
 (APN 178-190-200)
 POST MILE 10.83

SHEET C-3

DATE: 7-28-20
 DRAWN BY: CMK
 CHECKED BY: AZG
 REV. DATE:
 REV. DATE:
 REV. DATE:

Sigma Prime Geosciences, Inc.
 SIGMA PRIME GEOSCIENCES, INC.
 332 PRINCETON AVENUE
 HALF MOON BAY, CA 94019
 (650) 728-3590
 FAX 728-3593



SAN MATEO COUNTYWIDE

Water Pollution Prevention Program

Clean Water. Healthy Community.

Construction Best Management Practices (BMPs)

Construction projects are required to implement the stormwater best management practices (BMP) on this page, as they apply to your project, all year long.

Materials & Waste Management

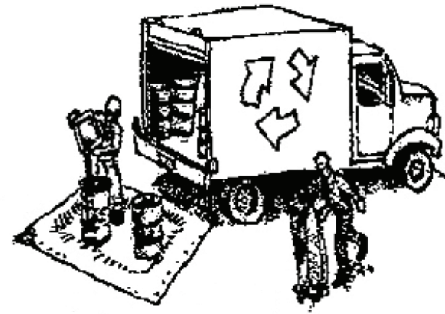

Non-Hazardous Materials

- Berm and cover stockpiles of sand, dirt or other construction material with tarps when rain is forecast or if not actively being used within 14 days.
- Use (but don't overuse) reclaimed water for dust control.

Hazardous Materials

- Label all hazardous materials and hazardous wastes (such as pesticides, paints, thinners, solvents, fuel, oil, and antifreeze) in accordance with city, county, state and federal regulations.
- Store hazardous materials and wastes in water tight containers, store in appropriate secondary containment, and cover them at the end of every work day or during wet weather or when rain is forecast.
- Follow manufacturer's application instructions for hazardous materials and be careful not to use more than necessary. Do not apply chemicals outdoors when rain is forecast within 24 hours.
- Arrange for appropriate disposal of all hazardous wastes.

Waste Management

- Cover waste disposal containers securely with tarps at the end of every work day and during wet weather.
- Check waste disposal containers frequently for leaks and to make sure they are not overfilled. Never hose down a dumpster on the construction site.
- Clean or replace portable toilets, and inspect them frequently for leaks and spills.
- Dispose of all wastes and debris properly. Recycle materials and wastes that can be recycled (such as asphalt, concrete, aggregate base materials, wood, gyp board, pipe, etc.)
- Dispose of liquid residues from paints, thinners, solvents, glues, and cleaning fluids as hazardous waste.

Construction Entrances and Perimeter

- Establish and maintain effective perimeter controls and stabilize all construction entrances and exits to sufficiently control erosion and sediment discharges from site and tracking off site.
- Sweep or vacuum any street tracking immediately and secure sediment source to prevent further tracking. Never hose down streets to clean up tracking.

Equipment Management & Spill Control



Maintenance and Parking

- Designate an area, fitted with appropriate BMPs, for vehicle and equipment parking and storage.
- Perform major maintenance, repair jobs, and vehicle and equipment washing off site.
- If refueling or vehicle maintenance must be done onsite, work in a bermed area away from storm drains and over a drip pan or drop cloths big enough to collect fluids. Recycle or dispose of fluids as hazardous waste.
- If vehicle or equipment cleaning must be done onsite, clean with water only in a bermed area that will not allow rinse water to run into gutters, streets, storm drains, or surface waters.
- Do not clean vehicle or equipment onsite using soaps, solvents, degreasers, or steam cleaning equipment.

Spill Prevention and Control

- Keep spill cleanup materials (e.g., rags, absorbents and cat litter) available at the construction site at all times.
- Inspect vehicles and equipment frequently for and repair leaks promptly. Use drip pans to catch leaks until repairs are made.
- Clean up spills or leaks immediately and dispose of cleanup materials properly.
- Do not hose down surfaces where fluids have spilled. Use dry cleanup methods (absorbent materials, cat litter, and/or rags).
- Sweep up spilled dry materials immediately. Do not try to wash them away with water, or bury them.
- Clean up spills on dirt areas by digging up and properly disposing of contaminated soil.
- Report significant spills immediately. You are required by law to report all significant releases of hazardous materials, including oil. To report a spill: 1) Dial 911 or your local emergency response number, 2) Call the Governor's Office of Emergency Services Warning Center, (800) 852-7550 (24 hours).

Earthmoving

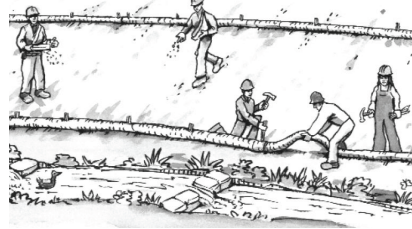

- Schedule grading and excavation work during dry weather.
- Stabilize all denuded areas, install and maintain temporary erosion controls (such as erosion control fabric or bonded fiber matrix) until vegetation is established.
- Remove existing vegetation only when absolutely necessary, and seed or plant vegetation for erosion control on slopes or where construction is not immediately planned.
- Prevent sediment from migrating offsite and protect storm drain inlets, gutters, ditches, and drainage courses by installing and maintaining appropriate BMPs, such as fiber rolls, silt fences, sediment basins, gravel bags, berms, etc.
- Keep excavated soil on site and transfer it to dump trucks on site, not in the streets.

Contaminated Soils

- If any of the following conditions are observed, test for contamination and contact the Regional Water Quality Control Board:
 - Unusual soil conditions, discoloration, or odor.
 - Abandoned underground tanks.
 - Abandoned wells
 - Buried barrels, debris, or trash.

Paving/Asphalt Work



- Avoid paving and seal coating in wet weather or when rain is forecast, to prevent materials that have not cured from contacting stormwater runoff.
- Cover storm drain inlets and manholes when applying seal coat, tack coat, slurry seal, fog seal, etc.
- Collect and recycle or appropriately dispose of excess abrasive gravel or sand. Do NOT sweep or wash it into gutters.
- Do not use water to wash down fresh asphalt concrete pavement.

Sawcutting & Asphalt/Concrete Removal

- Protect nearby storm drain inlets when saw cutting. Use filter fabric, catch basin inlet filters, or gravel bags to keep slurry out of the storm drain system.
- Shovel, absorb, or vacuum saw-cut slurry and dispose of all waste as soon as you are finished in one location or at the end of each work day (whichever is sooner!).
- If sawcut slurry enters a catch basin, clean it up immediately.

Concrete, Grout & Mortar Application



- Store concrete, grout, and mortar away from storm drains or waterways, and on pallets under cover to protect them from rain, runoff, and wind.
- Wash out concrete equipment/trucks offsite or in a designated washout area, where the water will flow into a temporary waste pit, and in a manner that will prevent leaching into the underlying soil or onto surrounding areas. Let concrete harden and dispose of as garbage.
- When washing exposed aggregate, prevent washwater from entering storm drains. Block any inlets and vacuum gutters, hose washwater onto dirt areas, or drain onto a bermed surface to be pumped and disposed of properly.

Landscaping

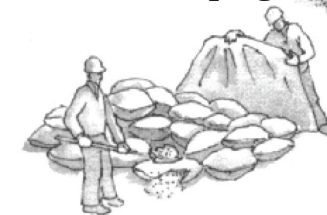

- Protect stockpiled landscaping materials from wind and rain by storing them under tarps all year-round.
- Stack bagged material on pallets and under cover.
- Discontinue application of any erodible landscape material within 2 days before a forecast rain event or during wet weather.

Painting & Paint Removal

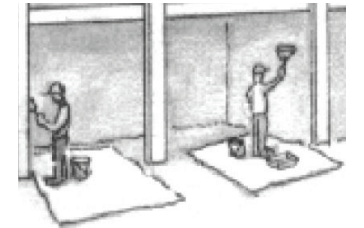

Painting Cleanup and Removal

- Never clean brushes or rinse paint containers into a street, gutter, storm drain, or stream.
- For water-based paints, paint out brushes to the extent possible, and rinse into a drain that goes to the sanitary sewer. Never pour paint down a storm drain.
- For oil-based paints, paint out brushes to the extent possible and clean with thinner or solvent in a proper container. Filter and reuse thinners and solvents. Dispose of excess liquids as hazardous waste.
- Paint chips and dust from non-hazardous dry stripping and sand blasting may be swept up or collected in plastic drop cloths and disposed of as trash.
- Chemical paint stripping residue and chips and dust from marine paints or paints containing lead, mercury, or tributyltin must be disposed of as hazardous waste. Lead based paint removal requires a state-certified contractor.

Dewatering

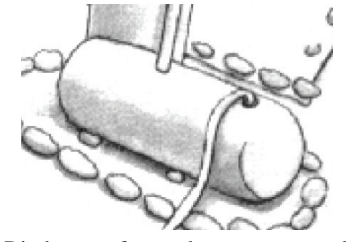

- Discharges of groundwater or captured runoff from dewatering operations must be properly managed and disposed. When possible send dewatering discharge to landscaped area or sanitary sewer. If discharging to the sanitary sewer call your local wastewater treatment plant.
- Divert run-on water from offsite away from all disturbed areas.
- When dewatering, notify and obtain approval from the local municipality before discharging water to a street gutter or storm drain. Filtration or diversion through a basin, tank, or sediment trap may be required.
- In areas of known or suspected contamination, call your local agency to determine whether the ground water must be tested. Pumped groundwater may need to be collected and hauled off-site for treatment and proper disposal.

Storm drain polluters may be liable for fines of up to \$10,000 per day!