

**COUNTY OF SAN MATEO
PLANNING AND BUILDING DEPARTMENT**

DATE: May 7, 2026

TO: Zoning Hearing Officer

FROM: Planning Staff

SUBJECT: Consideration of a Use Permit, pursuant to Section 8.376.030 of the San Mateo County Zoning Regulations, for the installation of an AT&T small cell wireless communications facility within the Cordilleras Road public right-of-way, near Cordilleras Road, on a PG&E-owned utility pole. The existing pole would be replaced, and all associated equipment would be mounted on the replacement pole.

County File Number: PLN2025-00235 (NextEdge Networks)

PROPOSAL

The applicant proposes installing an AT&T small cell wireless communications facility within the Cordilleras Road public right-of-way on a Pacific Gas and Electric Company (PG&E) owned utility pole. The scope of work includes replacing the existing 24-foot-11-inch-tall wooden utility pole with a new 35-foot-11-inch-tall wood pole to accommodate upgraded telecommunications equipment. The project involves installing one new 2-foot canister antenna at the top of the new pole, as well as two new radios (models 4490 and 4890) and two AC08 power supply units mounted on the pole. Supporting infrastructure would include a new coaxial conduit connecting the antenna to the equipment, a new power conduit and a new fiber conduit extending from the point of connection to the equipment. Additional components to be installed include a new equipment bracket, a smart meter with disconnect, and a fiber box. No ground-mounted equipment or equipment cabinets are proposed. The applicant notes that all cabling would be installed in a neat and orderly manner, with no excess loops. All AT&T-installed equipment and appurtenances would be painted to match the utility pole using a non-glossy "Sable" color by Sherwin Williams or an equivalent.

RECOMMENDATION

That the Zoning Hearing Officer approve the Use Permit, PLN2025-00235, by making the required findings and adopting the conditions of approval listed in Attachment A.

BACKGROUND

Report Prepared By: Luis Topete, Project Planner

Applicant: Tasha Stack, NextEdge Networks

Owner: Pacific Gas and Electric Company (PG&E)

Public Notification: A ten-day advanced notification for the hearing was mailed to all property owners within 300 feet of the project's perimeter, and a hearing notice was published in the San Mateo County Times, a newspaper of general public circulation.

Location: Near 1888 Cordilleras Road, Emerald Hills, CA 94062
(Latitude: 37.473252°N; Longitude: 122.266346°W)

APN: Near 057-052-190

Size: Not applicable. In the public right-of-way.

Existing Zoning: RH/DR (Residential Hillside District/Design Review District)

General Plan: Low Density Residential

Sphere-of-Influence: City of Redwood City

Existing Land Use: PG&E utility pole

Water Supply: Not within the service area of a public water supplier.

Sewage Disposal: Emerald Lakes Sewer District

Flood Zone: Zone X (Area of Minimal Flood Hazard). FEMA FIRM Panel 06081C0282E. Effective Date: October 16, 2012.

Seismic Hazard Zone: Liquefaction Zone

Environmental Evaluation: The project is categorically exempt from the California Environmental Quality Act (CEQA), pursuant to CEQA Guidelines Section 15303, Class 3, relating to the construction and location of new small facilities or structures and installation of small new equipment and facilities in small structures.

Setting: The existing PG&E wooden utility pole is located within the public right-of-way on the north side of Cordilleras Road, near the southwest corner of the driveway entrance to 1888 Cordilleras Road, in the unincorporated community of Emerald Lake Hills. The existing pole stands 24 feet, 11 inches tall. The project site is in a residential area, with several trees located behind the existing pole. To the south, across Cordilleras Road, are additional residential properties and rolling hills.

Chronology:

<u>Date</u>	<u>Action</u>
July 22, 2025	- Application submitted.
March 6, 2026	- Application deemed complete.
May 7, 2026	- Zoning Hearing Officer public hearing.

DISCUSSION

A. KEY ISSUES

1. Compliance with the County General Plan

Staff has reviewed the project and found it to be compliant with the policies of the General Plan. The relevant policies are discussed below:

a. Visual Quality Policies

Policy 4.21 (*Utility Structures*) seeks to minimize the adverse visual impact of utility structures. The project is not located within a County-designated scenic route or within a State- or County-designated scenic corridor. To reduce visual impact, the existing wood utility pole would be replaced with a new wood pole in the same location, with all AT&T-added equipment painted to match the pole, reducing visual contrast. No ground-mounted equipment or equipment cabinets are proposed. Equipment would be mounted close to the pole and grouped to minimize bulk. Existing trees and roadside vegetation would screen the facility, and no vegetation would be removed. Although the replacement pole would be taller, its design maintains minimal visibility compared to the existing facility while addressing the service gap. No tree removal, grading, or disturbance to existing vegetation is proposed.

b. Man-Made Hazards Policies

Policy 16.12 (*Regulate Noise Levels*) directs the County to regulate noise levels emanating from noise generating land uses. The County of San Mateo outlines exterior noise level standards in Section 4.88.330 of the Code of Ordinances. A Noise Assessment was provided which calculated the sound pressure levels from the proposed equipment when measured at the nearest property line from the proposed noise sources. The analysis concludes that the noise produced from operation of the proposed equipment would comply with the County's exterior noise level standards outlined in Section 4.88.330. Further, the site design does not include installation of emergency back-up generators, equipment cabinets, or other noise-generating equipment typically associated with traditional wireless telecommunications sites, and the proposed installations would not utilize any external alarms.

2. Compliance with the Zoning Regulations

The project site is located within the Cordilleras Road public right-of-way in an area of the County zoned RH/DR (Residential Hillside District / Design Review District). While the area is within a designated zoning district, the RH District zoning standards, except for applicable height limits as specified under Chapter 8.376 (Wireless Telecommunication Facilities), do not apply to wireless facilities located in the public right-of-way. In the RH District, the maximum permitted building height is 28 feet; however, mechanical equipment, antennas, and similar facilities may exceed this limit up to a maximum of 36 feet when necessary for safe or efficient operation. The proposed replacement pole and associated equipment would be 35 feet, 11 inches tall. Design Review regulations do not apply to wireless telecommunication facilities in the public right-of-way, as these facilities are subject to separate standards and visual impact criteria established under Chapter 8.376.

The proposed pole height is below the County's standard limit. According to the applicant, the installation must comply with applicable state safety requirements, including California Public Utilities Commission General Order 95 (GO 95). GO 95 and PG&E standards establish mandatory minimum clearances and attachment heights for telecommunications equipment. Where compliance requires a taller pole, the County's height limit cannot preclude installation necessary to meet those state safety requirements. Under federal law, local regulations constitute an effective prohibition if they materially inhibit a provider's ability to deploy or improve its network. The facility is designed at the minimum height necessary to address a service gap and qualifies as a "small wireless facility" under the Federal Communications Commission (FCC) 2018 Small Cell Order, as it is

mounted on a structure under 50 feet in total height and complies with applicable equipment size limits.

3. Compliance with the Wireless Telecommunications Facilities Ordinance

Staff has determined that the project complies with applicable standards of the Wireless Telecommunications Facilities Ordinance, Chapter 8.376 of the San Mateo County Zoning Ordinance, as discussed below:

a. Development and Design Standards

All new wireless telecommunication facilities must meet the following minimum standards. Where appropriate, more restrictive requirements may be imposed as a condition of Use Permit approval.

- (1) **New wireless telecommunication facilities shall be prohibited in a Sensitive Habitat, as defined by Policy 1.8 of the General Plan (*Definition of Sensitive Habitats*) for facilities proposed outside of the Coastal Zone, and by Policy 7.1 of the Local Coastal Program (*Definition of Sensitive Habitats*) for facilities proposed in the Coastal Zone, except when all of the written findings identified in Section 8.376.030(II)(A) are made by the reviewing authority.**

Policy 1.8 of the General Plan defines sensitive habitat as any area where the vegetative, water, fish, and wildlife resources provide especially valuable and rare plant and animal habitats that can be easily disturbed or degraded. The proposed pole would replace the existing utility pole in the same location. The project is within the mapped urban boundary surrounded by existing development. The County's California Natural Diversity Database (CNDDB) mapping layer does not identify any plant or animal species listed as special-status under State or Federal regulations. The project is not located within an area defined by Policy 1.8 of the General Plan as sensitive habitat.

- (2) **New wireless telecommunication facilities shall not be located in areas zoned Residential (R), unless the applicant demonstrates, by a preponderance of the evidence, that a review has been conducted of other options, and no other sites or combination of sites allows feasible service or adequate capacity and coverage. This review shall include, but is not limited to, identification of alternative site(s) within 2.5 miles of the proposed facility. See Section 8.376.030(V) for additional application requirements.**

The proposed small wireless facility would be located on a utility pole within the public right-of-way in a residential zoning district. The applicant submitted a co-location assessment, alternative site analysis, and wireless coverage maps demonstrating that the proposed facility represents the least intrusive means of addressing an identified coverage gap. AT&T evaluated eight alternative PG&E distribution pole locations. Each was reviewed for compliance with PG&E's mandatory engineering standards for third-party wireless attachments (PG&E Standard 027911) and the CPUC General Order 95. All alternatives were eliminated due to disqualifying conditions under these requirements. The proposed location was determined to be the only site that satisfies applicable PG&E engineering standards and therefore represents the least intrusive feasible means of closing the identified coverage gap.

- (3) **New wireless telecommunication facilities shall not be located in areas where co-location on existing facilities would provide equivalent coverage with less environmental impact.**

AT&T conducted a comprehensive co-location assessment of all existing wireless infrastructure within a 2.5-mile radius of the Emerald Hills service area. Every existing structure was eliminated as a co-location candidate. In terrain characterized by steep hillside topography and dense tree canopy, a small cell's effective coverage radius is limited to approximately 500–1,000 feet. No existing structure is positioned to provide the street-level, in-building coverage required to close the gap.

- (4) **Except where aesthetically inappropriate, new wireless telecommunication facilities must be constructed so as to accommodate co-location, and must be made available for co-location unless technologically infeasible.**

The pole is not a traditional monopole and is not designed to support additional wireless equipment. As a result, co-location of equipment from other carriers is technologically infeasible.

- (5) **The adverse visual impact of utility structures shall be avoided by: (1) siting new wireless telecommunication facilities outside of public viewshed whenever feasible; (2) maximizing the use of existing vegetation and natural features to cloak wireless telecommunication facilities; and (3) constructing towers no taller than necessary to provide adequate coverage. When visual impacts cannot be**

avoided, they shall be minimized and mitigated as detailed in 8.376.030(II)(E).

The proposed small cell wireless facility would be located within the public right-of-way, mounted on a replacement wooden utility pole at the same location as the existing pole. Although situated in a developed roadway corridor, the presence of existing trees and roadside vegetation helps visually integrate the facility into the surrounding environment. The facility's design avoids the removal of vegetation and takes advantage of existing natural features for screening. The facility is designed at the minimum height necessary to address a service gap. Unlike traditional monopole wireless facilities, this installation does not include ground equipment or equipment cabinets that would require landscape screening. All equipment and appurtenances would be painted to match the wooden utility pole, helping the facility blend with the surrounding environment and existing utility infrastructure while reducing visual contrast. Additionally, equipment would be mounted closely to the pole and grouped to minimize bulk.

- (6) Paint colors for the wireless telecommunication facility shall minimize its visual impact by blending with the surrounding environment and/or buildings. Prior to the issuance of a building permit, the applicant shall submit color samples for the wireless telecommunication facility. Paint colors shall be subject to the review and approval of the Planning and Building Department. Color verification shall occur in the field after the applicant has painted the equipment the approved color, but before the applicant schedules a final inspection.**

All AT&T-installed equipment and appurtenances would be painted to match the utility pole using a non-glossy "Sable" color by Sherwin Williams or an equivalent.

- (7) The exteriors of wireless telecommunication facilities shall be constructed of nonreflective materials.**

The replacement pole would be made of wood and the proposed equipment would be painted in Sherwin-Williams' "Sable" (SW 6083), a deep, warm brown with a Light Reflectance Value (LRV) of approximately 8, indicating it absorbs most light and appears quite dark. A non-glossy sheen has been proposed, although the exact finish was not specified. To ensure a non-

reflective appearance, the applicant would be required to use a flat or matte finish. (Condition No.6)

- (8) **The wireless telecommunication facility shall comply with all the requirements of the underlying zoning district(s), including, but not limited to, setbacks, Design Review in the DR district(s), Architectural Review in designated Scenic Corridors, and Coastal Development Permit regulations in the CZ or CD zones.**

See Section A.2 for a detailed discussion of the project's compliance with applicable Zoning Regulations. The project site is not located within a State- or County-designated scenic corridor and is outside the Coastal Zone. Design Review regulations do not apply to wireless telecommunication facilities in the public right-of-way, as these facilities are subject to separate standards and visual impact criteria established under Chapter 8.376.

- (9) **Except as otherwise provided in 8.376.030(II)(I), ground-mounted towers, spires and similar structures may be built and used to a greater height than the limit established for the zoning district in which the structure is located; provided that no such exception shall cover, at any level, more than 15% in area of the lot nor have an area at the base greater than 1,600 sq. ft.; provided, further that no tower, spire or similar structure in any district shall ever exceed a maximum height of 150 feet.**

See Section A.2 for a detailed discussion of the project's compliance with height requirements.

- (10) **In any Residential (R) district, accessory buildings in support of the operation of the wireless telecommunication facility may be constructed, provided that they comply with the provisions of Chapter 8.348 regarding accessory buildings, except that the building coverage and floor area maximums shall apply to buildings in aggregate, rather than individually.**

No accessory buildings are proposed as part of the project.

- (11) **In any Residential (R) district, ground-mounted towers, spires and similar structures may be built and used provided that they shall not cover, in combination with any accessory building(s), shelter(s), or cabinet(s) or other above-ground equipment used in support of the operation of the wireless telecommunication facility, more than 15% in area of the lot nor an area greater than 1,600 sq. ft. Buildings, shelters, and cabinets shall be grouped. Towers, spires, and poles shall also be grouped, to the extent feasible for the technology.**

The replacement pole would have a diameter of approximately one foot. When viewed from above, the pole and all associated equipment and appurtenances, generally grouped along the same side of the pole, would occupy less than two square feet in total area.

- (12) **Diesel generators shall not be installed as an emergency power source unless the use of electricity, natural gas, solar, wind or other renewable energy sources are not feasible. If a diesel generator is proposed, the applicant shall provide written documentation as to why the installation of options such as electricity, natural gas, solar, wind or other renewable energy sources is not feasible.**

The proposal does not include the installation of an emergency back-up generator typically associated with traditional wireless telecommunications sites.

b. Performance Standards

All new wireless telecommunication facilities that are not co-location facilities must comply with the performance standards outlined in Section 8.376.030.III. These standards include, but are not limited to, requirements related to lighting, licensing and registration, building permits, provision of a permanent power source, ongoing maintenance, and the timely removal of the facility if it is abandoned or if its license or registration is revoked. While several of these standards cannot be reviewed for compliance at this time as they apply to the performance of the facility, they remain enforceable obligations and have been incorporated as conditions of approval (Conditions No.10-15) to ensure future compliance.

No lighting is proposed as part of this project. The applicant is required to obtain and maintain all necessary licenses and registrations from

the FCC, the CPUC, and any other relevant regulatory agencies prior to beginning operation of the facility.

Existing site access would be utilized. According to the submitted Noise Assessment, noise generated by the proposed equipment would comply with the County's exterior noise level limits specified in Section 4.88.330. Additionally, the project design does not include emergency backup generators, equipment cabinets, or other noise-generating equipment typically associated with traditional wireless telecommunications sites, and the project would not utilize any external alarms.

4. Compliance with the Use Permit Findings

The applicant is seeking a Use Permit to construct a new wireless telecommunications facility. The granting of a Use Permit is subject to the following findings:

- a. **That the establishment, maintenance, and/or conducting of the use will not, under the circumstances of the particular case, result in significant adverse impact to coastal resources, or be detrimental to the public welfare or injurious to property or improvements in said neighborhood.**

The project is located within the mapped urban boundary and is surrounded by existing development. The site is outside the Coastal Zone and not located within any State- or County-designated scenic corridor. The California Natural Diversity Database (CNDDDB) mapping layer does not identify the site as containing special-status species or sensitive habitats, and the project is not located within an area defined by Policy 1.8 of the General Plan as sensitive habitat.

To minimize visual impacts, the project involves replacing an existing wood utility pole with a similar wood pole in the same location and painting all associated AT&T equipment to match the pole. No tree removal, grading, or disturbance to vegetation is proposed. A noise assessment confirms that the project complies with County noise standards (Section 4.88.330), and the design avoids the use of back-up generators, equipment cabinets, or other typical noise-generating components. In addition, the proposed facility would operate in compliance with applicable FCC radiofrequency exposure limits.

A traffic control plan has been provided demonstrating how traffic, pedestrians, and cyclists would be safely managed during construction, including lane closures, signage, and detours, to minimize disruption and maintain public safety. Additionally, Condition

3 requires that, prior to start of work, tree protection fencing shall be installed to protect trees within the area of project disturbance.

Therefore, the project would not adversely affect environmental resources or public welfare.

b. **That this telecommunications facility is necessary for the public health, safety, convenience or welfare.**

The facility would enhance wireless service in the area, where AT&T has identified a significant coverage gap, ensuring improved connectivity and coverage, which are critical for emergency services, public safety, and access to vital communication networks. The increased capacity would support the growing demand for reliable mobile services, particularly in areas with limited coverage or high demand. Additionally, the facility would comply with all applicable regulations and safety standards, contributing to the overall well-being and convenience of the public.

B. ENVIRONMENTAL REVIEW

The project is categorically exempt from the California Environmental Quality Act (CEQA), pursuant to CEQA Guidelines Section 15303, Class 3, relating to the construction and location of new small facilities or structures and installation of small new equipment and facilities in small structures. The small cell wireless communications facility would involve replacement of the existing wooden utility pole with a new wood pole to accommodate upgraded telecommunications equipment that would be mounted on the replacement pole. The project is not located within a County-designated scenic route or within a State- or County-designated scenic corridor. The project attempts to minimize the adverse visual quality of the utility pole and equipment by replacing the existing wood utility pole with another wood utility pole in the same location and painting all AT&T-added appurtenances to match the pole color. No tree removal, grading, or disturbance to existing vegetation is proposed. Further, the facility would comply with the Federal FCC Radiofrequency Radiation Exposure Limits set forth in 47 C.F.R. §§ 1.1307(b)(3) and 1.1310.

C. REVIEWING AGENCIES

Building Department
County Fire Department
Department of Public Works

ATTACHMENTS

- A. Recommended Findings and Conditions of Approval
- B. Location Map
- C. Vicinity Map
- D. Plans
- E. Photosimulations
- F. Alternative Site Analysis
- G. Co-location Assessment
- H. Radio Frequency Emissions Compliance Report
- I. Noise Study

County of San Mateo
Planning and Building Department

RECOMMENDED FINDINGS AND CONDITIONS OF APPROVAL

Permit or Project File Number: PLN2025-00235

Hearing Date: May 7, 2026

Prepared By: Luis Topete, Project Planner

For Adoption By: Zoning Hearing Officer

RECOMMENDED FINDINGS

For the Environmental Review, Find:

1. That the project is categorically exempt from the California Environmental Quality Act (CEQA), pursuant to CEQA Guidelines Section 15303, Class 3, relating to the construction and location of new small facilities or structures and installation of small new equipment and facilities in small structures.

For the Use Permit, Find:

2. That the establishment, maintenance, and/or conducting of the use will not, under the circumstances of the particular case, result in significant adverse impact to coastal resources, or be detrimental to the public welfare or injurious to property or improvements in said neighborhood. See Section A.4.a for a detailed discussion.
3. That this telecommunications facility is necessary for the public health, safety, convenience or welfare. See Section A.4.b for a detailed discussion.

RECOMMENDED CONDITIONS OF APPROVAL

Current Planning Section

1. This approval only applies to the proposal, documents, and plans described in this report, and submitted to and approved by the Zoning Hearing Officer on May 7, 2026. Modifications beyond those approved by the Zoning Hearing Officer will be subject to review and approval by the Director of Planning and Building and may require review at a public hearing. Minor modifications that are largely consistent with this approval may be approved at the discretion of the Director of Planning and Building.

2. This Use Permit shall be valid for 10 years following the date of final approval. The applicant shall file for a renewal of the Use Permit and pay the applicable renewal application fees six months prior to expiration with the County Planning and Building Department, if continuation of the use is desired.
3. This permit does not allow for the removal or trimming of any trees. Any tree removal will require a separate permitting process. Prior to start of work, tree protection fencing shall be installed to protect trees within the area of project disturbance.
4. Prior to issuance of the building permit, plans shall demonstrate that access controls with appropriate RF alerting signage will be put in place and maintained to restrict access to authorized personnel. Upon final of the building permit, signage must be posted to be visible upon approach from any direction to provide notification of potential conditions within these areas.
5. The facility shall be maintained in good working condition and to the visual standards established at the time of approval over the life of this permit. The facility and surrounding area shall remain free from trash, debris, litter, graffiti, and other forms of vandalism. Any facility damage shall be repaired as soon as is practicable, and in no instance more than ten calendar days from the time of notification by the County or after discovery by the permit holder.

Development and Design Standards

6. All equipment and appurtenances shall be painted to match the utility pole using Sherwin Williams' non-glossy "Sable" color or an equivalent. To ensure a non-reflective appearance, a flat or matte finish shall be used.
7. Prior to the issuance of a building permit, the applicant shall submit color samples for the wireless telecommunication facility. Paint colors shall be subject to the review and approval of the Planning and Building Department. Color verification shall occur in the field after the applicant has painted the equipment the approved color, but before the applicant schedules a final inspection.
8. The exteriors of wireless telecommunication facilities shall be constructed of nonreflective materials.
9. Diesel generators shall not be installed as an emergency power source unless the use of electricity, natural gas, solar, wind or other renewable energy sources are not feasible. If a diesel generator is proposed, the applicant shall provide written documentation as to why the installation of options such as electricity, natural gas, solar, wind or other renewable energy sources is not feasible. Installation of a diesel generator may require a Major Amendment to this Use Permit if the modification would result in increased noise, odors, or other potential impacts beyond those analyzed in the staff report for the approved project.

Performance Standards

10. Wireless telecommunication facilities shall not be lighted or marked unless required by the Federal Communications Commission (FCC) or the Federal Aviation Administration (FAA).
11. The applicant shall file, receive, and maintain all necessary licenses and registrations from the Federal Communications Commission (FCC), the California Public Utilities Commission (CPUC) and any other applicable regulatory bodies prior to initiating the operation of the wireless telecommunication facility. The applicant shall supply the Planning and Building Department with evidence of these licenses and registrations. If any required license is ever revoked, the applicant shall inform the Planning and Building Department of the revocation within 10 days of receiving notice of such revocation.
12. Once a use permit is obtained, the applicant shall obtain a building permit and build in accordance with the approved plans.
13. The project's final inspection approval shall be dependent upon the applicant obtaining a permanent and operable power connection from the applicable energy provider.
14. The wireless telecommunication facility and all equipment associated with it shall be removed in its entirety by the applicant within 90 days if the FCC and/or CPUC license and registration are revoked or the facility is abandoned or no longer needed, and the site shall be restored and revegetated to blend with the surrounding area. The owner and/or operator of the wireless telecommunication facility shall notify the County Planning Department upon abandonment of the facility. Restoration and revegetation shall be completed within two months of the removal of the facility.
15. Wireless telecommunication facilities shall be maintained by the permittee(s) and subsequent owners in a manner that implements visual resource protection requirements of the County's Wireless Telecommunications Facilities Ordinance, as well as all other applicable zoning standards and permit conditions.

Building Inspection Section

16. A building permit shall be applied for and obtained from the Building Inspection Section prior to the start of any work.

County Fire Department

17. Weeds, grass, vines or other growth that is capable of being ignited and endangering property, shall be cut down and removed by the owner or occupant

of the premises. Vegetation clearance requirements in wildland-urban interface areas shall be in accordance with Chapter 49.

18. Hazardous vegetation and fuels shall be managed to reduce the severity of potential exterior wildfire exposure to buildings and to reduce the risk of fire spreading to buildings as required by applicable laws and regulations. Defensible space will be managed around all buildings and structures in State Responsibility Areas (SRA) as required in Public Resources Code 4291.
19. All fire conditions and requirements must be incorporated into your building plans, prior to building permit issuance. It is your responsibility to notify your contractor, architect and engineer of these requirements.

Department of Public Works

20. No proposed construction work within the County right-of-way shall begin until County requirements for the issuance of an encroachment permit, including review of the plans, have been met and an encroachment permit issued. Applicant shall contact a Department of Public Works Inspector 48 hours prior to commencing work in the right-of-way.



COUNTY OF SAN MATEO - PLANNING AND BUILDING DEPARTMENT

ATTACHMENT B

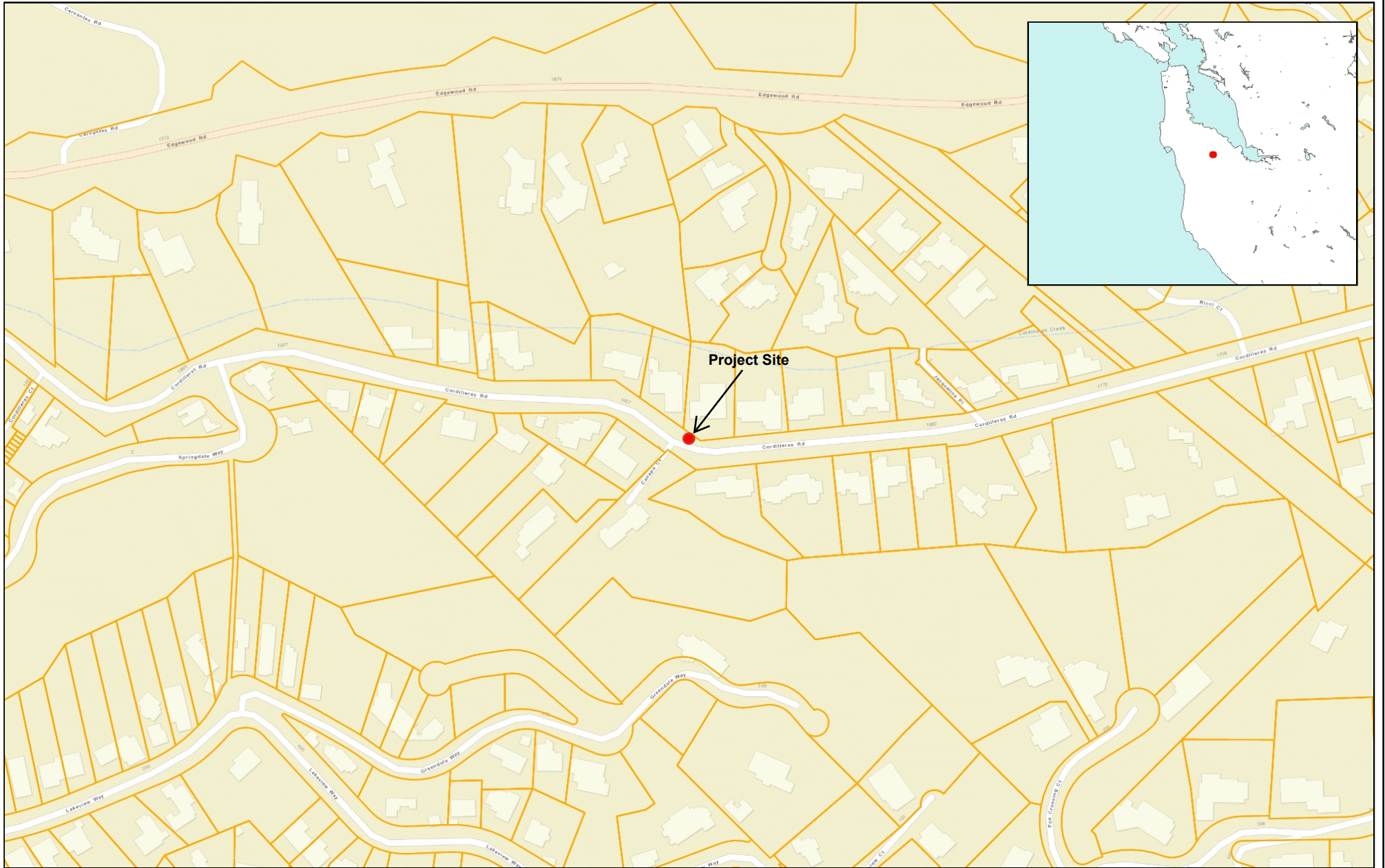

0.12 0 0.06 0.12 Miles

WGS_1984_Web_Mercator_Auxiliary_Sphere
© Latitude Geographics Group Ltd.

1:3,646



This map is a user generated static output from an Internet mapping site and is for reference only. Data layers that appear on this map may or may not be accurate, current, or otherwise reliable.

THIS MAP IS NOT TO BE USED FOR NAVIGATION



COUNTY OF SAN MATEO - PLANNING AND BUILDING DEPARTMENT

ATTACHMENT C

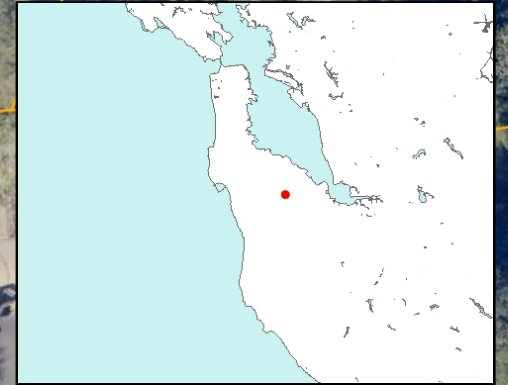

0.03 0 0.01 0.03 Miles

WGS_1984_Web_Mercator_Auxiliary_Sphere
© Latitude Geographics Group Ltd.

1:911 

This map is a user generated static output from an Internet mapping site and is for reference only. Data layers that appear on this map may or may not be accurate, current, or otherwise reliable.

THIS MAP IS NOT TO BE USED FOR NAVIGATION



COUNTY OF SAN MATEO - PLANNING AND BUILDING DEPARTMENT

ATTACHMENT D

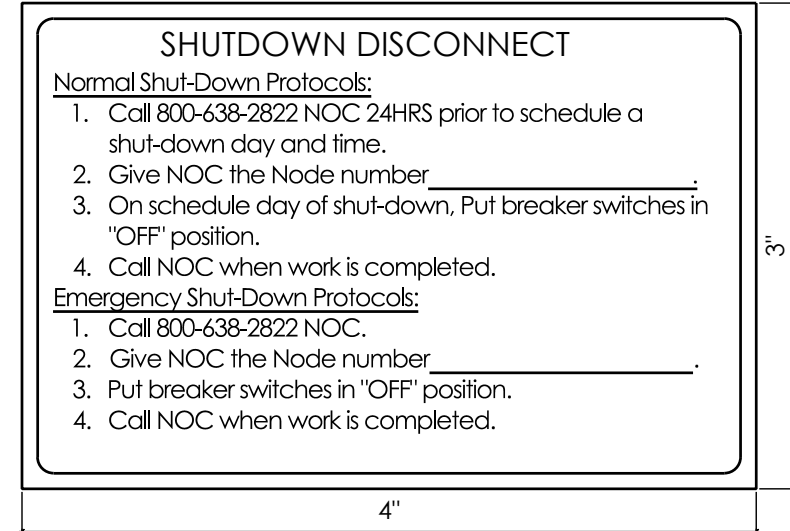

- NOTES:**
- SIGN PROVIDED BY GC, MOUNTED TO OUTSIDE OF DISCONNECT COVER
 - CONTRACTOR TO NOTE MARKET ID, SITE ID, SITE NAME

SHUTDOWN SIGNAGE

SCALE: NTS

12 NOT USED

FCC SIGNAGE

SCALE: NTS

11

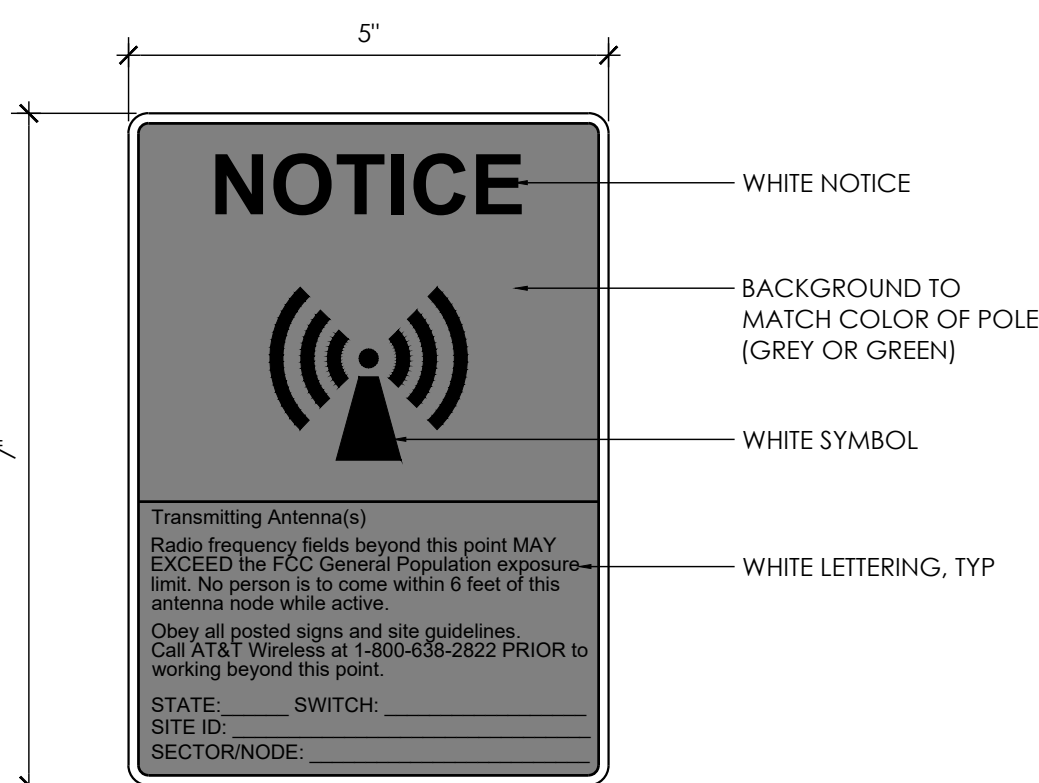

- NOTES:**
- OUTDOOR RATED SELF ADHESIVE VINYL DECAL WITH UV PROTECTION.
 - POST SIGN 3'-0" BELOW PROPOSED ANTENNA.
 - CONTRACTOR TO CONFIRM SPECIFIC SIGN REQUIREMENTS WITH AT&T WIRELESS, AND PUBLIC UTILITIES COMMISSION AND AUTHORITIES HAVING JURISDICTION PRIOR TO FABRICATION.
 - DECAL SHALL FACE OUT THE STREET AND WHEN FEASIBLE AWAY FROM THE STREET, IF NO BUILDING WINDOW IS PRESENT WITHIN 25 FEET FACING THE EXISTING POLE.

NOT USED

SCALE: NTS

10 ANTENNA BRACKET

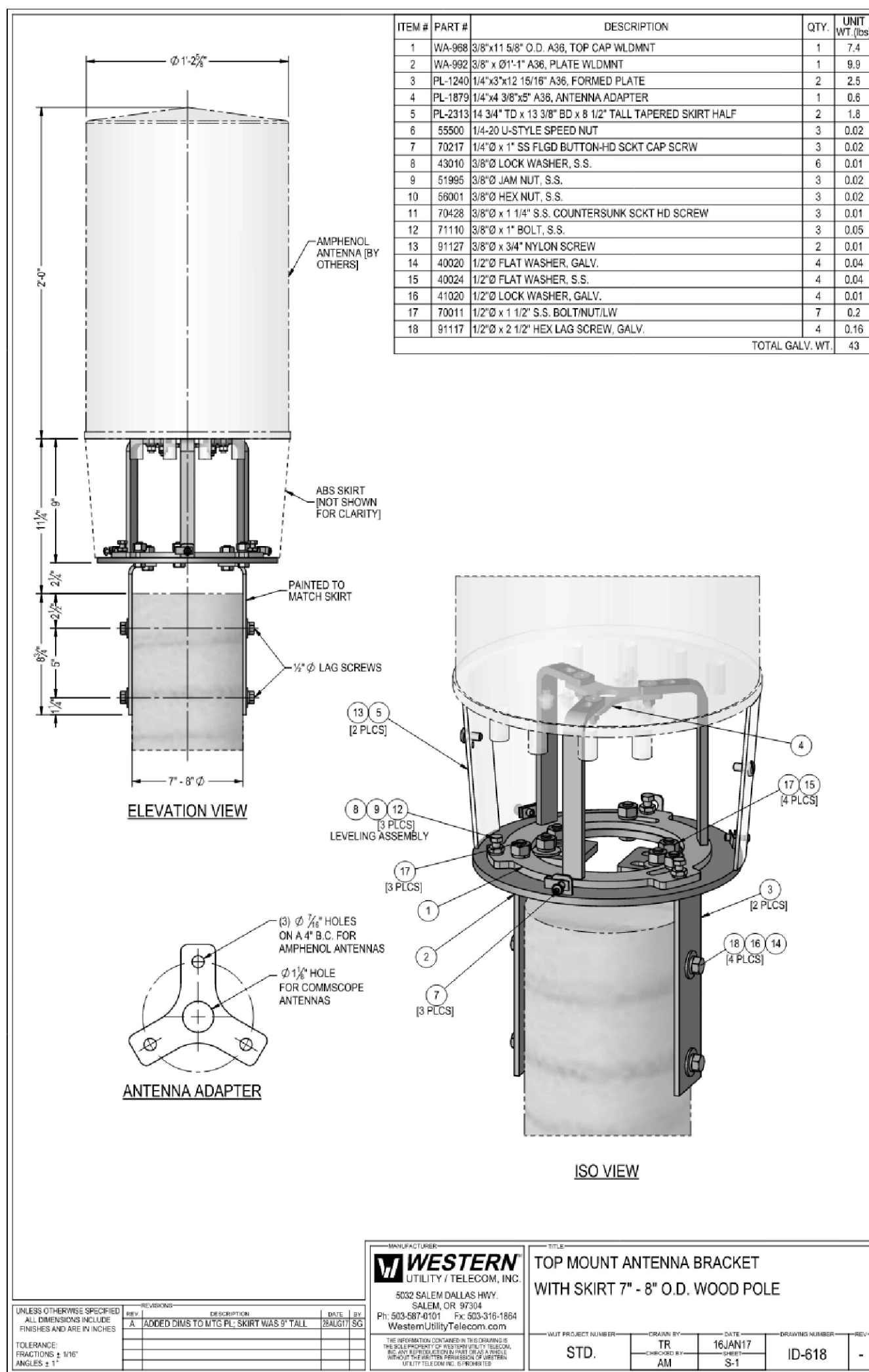

NOT USED

SCALE: NTS

10 ANTENNA BRACKET

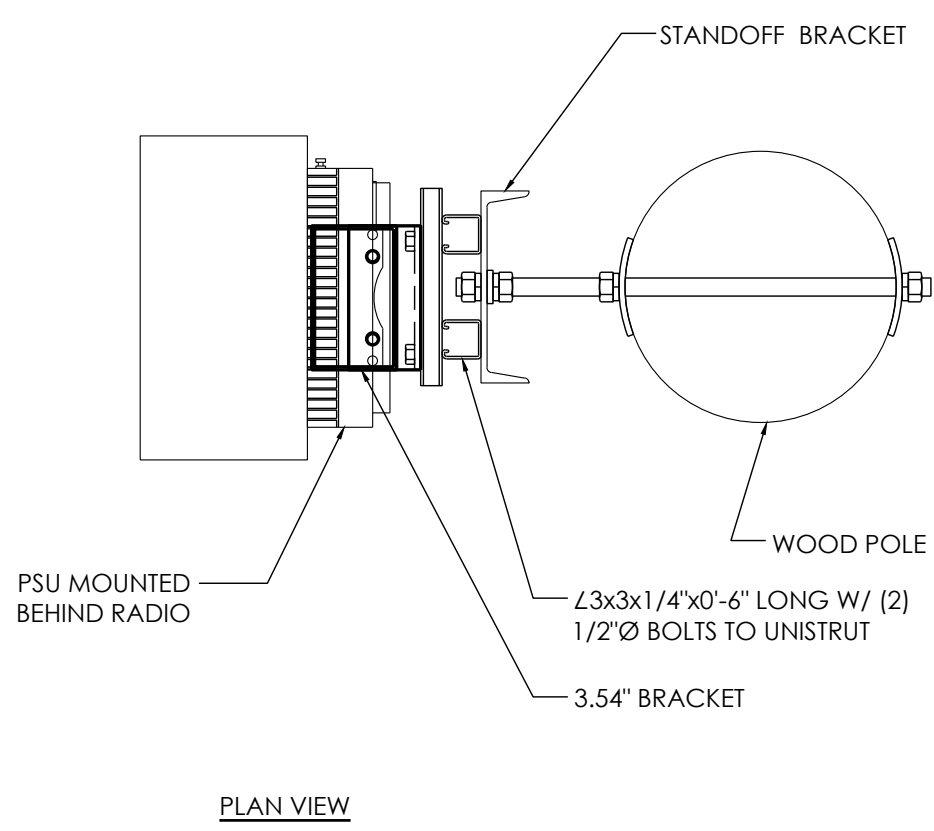

RADIO MOUNT

SCALE: NTS

9

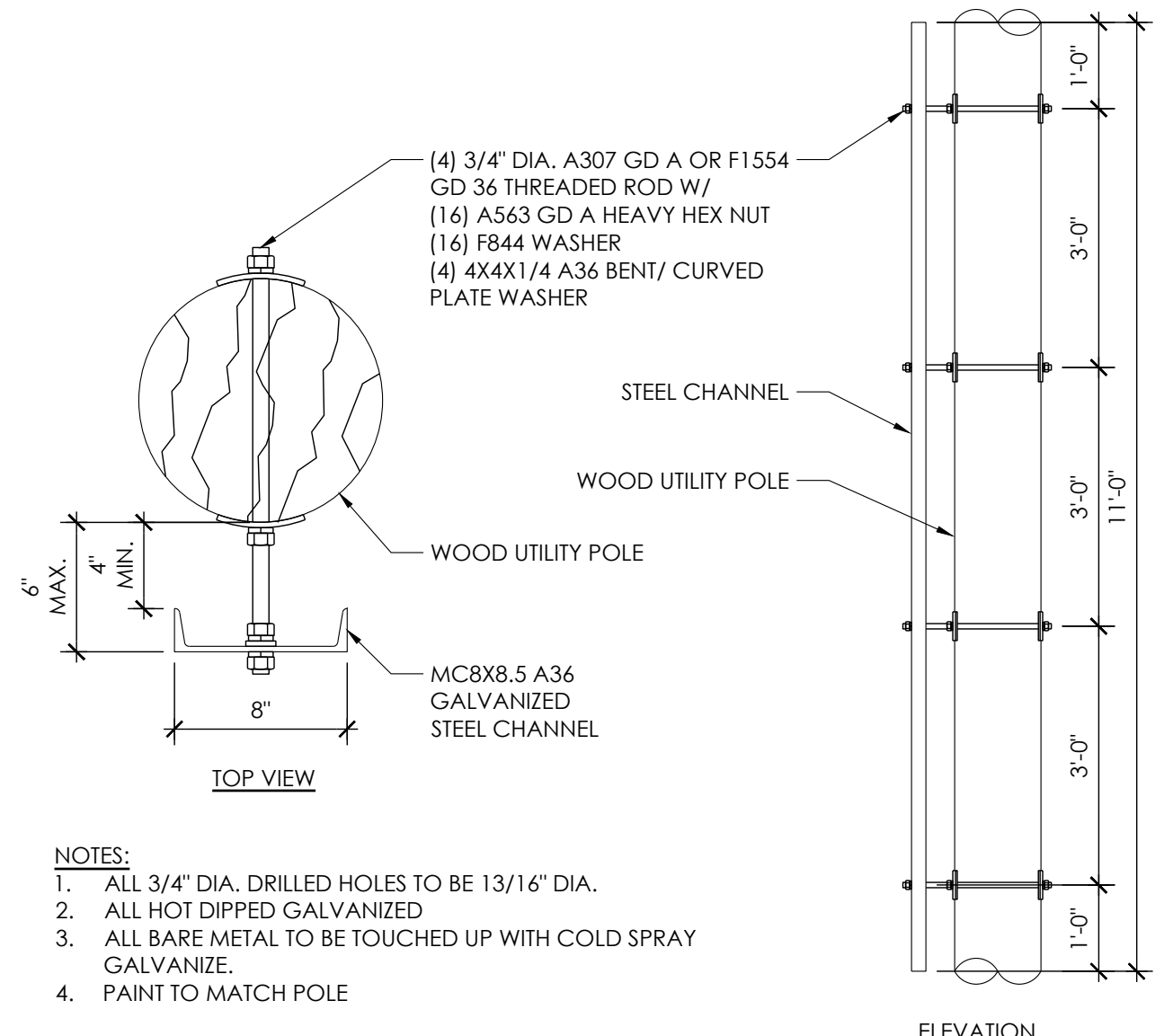

STANDOFF BRACKET

SCALE: NTS

5

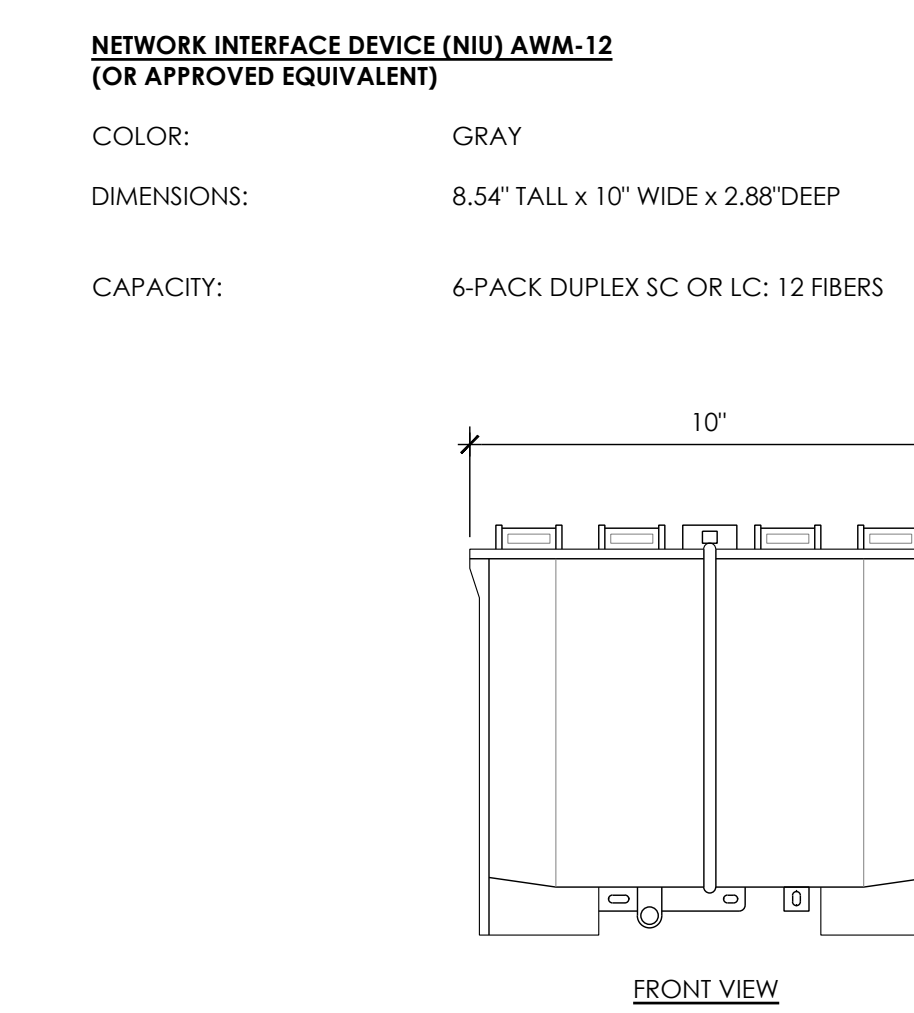

FIBER BOX

SCALE: NTS

7

RADIO 4490 (OR APPROVED EQUAL)
 COLOR: GRAY
 DIMENSIONS: 16.5" TALL x 14.8" WIDE x 6.3" DEEP
 WEIGHT: 57.48 LBS

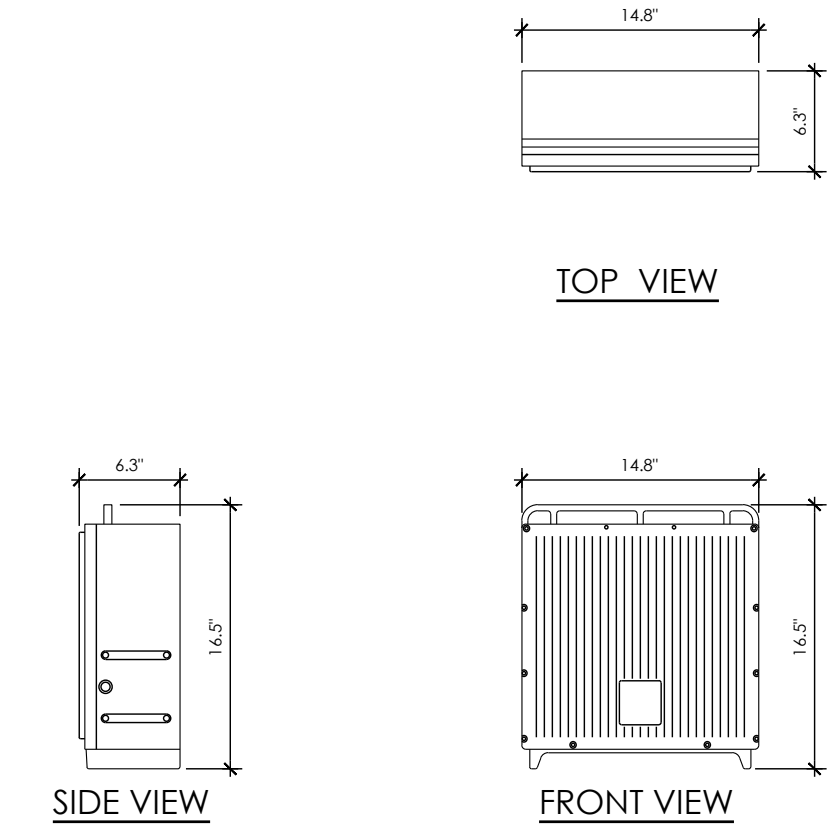

RADIO 4490

SCALE: NTS

6

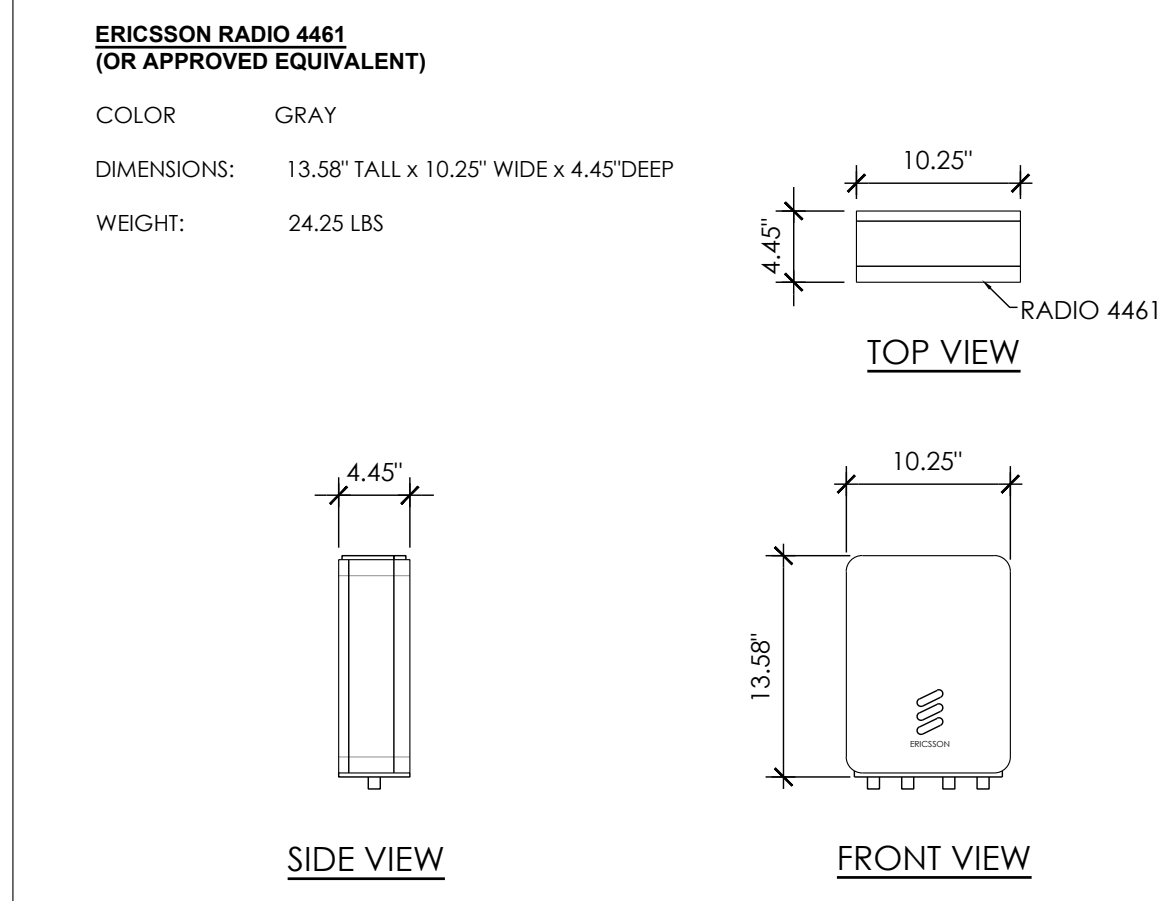

RADIO 4890

SCALE: NTS

2

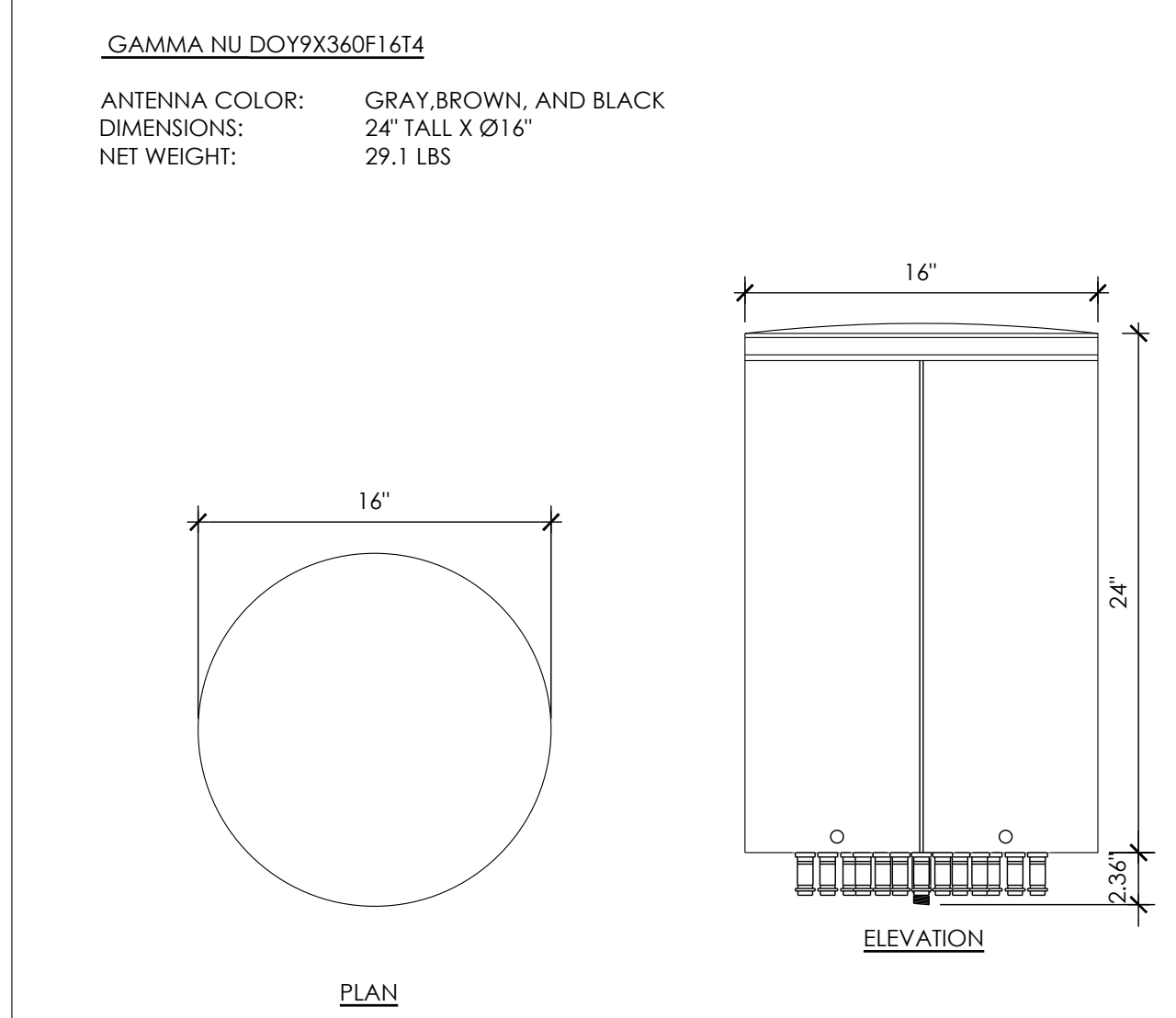

ANTENNA

SCALE: NTS

4

DRAWN BY:	JLV
CHECKED BY:	TDL
APPROVED BY:	CW

REV	DATE	DESCRIPTION
A	05/12/25	90% CD
0	05/22/25	100% CD

CRAN_RSFR_PAPK1_05
 (NEAR) 1888 CORDILLERAS RD
 EMERALD HILLS, CA 94062

DETAILS

D-1

ANTENNA

SCALE: NTS

1



COUNTY OF SAN MATEO - PLANNING AND BUILDING DEPARTMENT

ATTACHMENT E

CRAN_RSFR_PAPK1_05
NEAR 1888 CORDILLERAS RD
REDWOOD CITY, CA 94062

EXISTING



PROPOSED

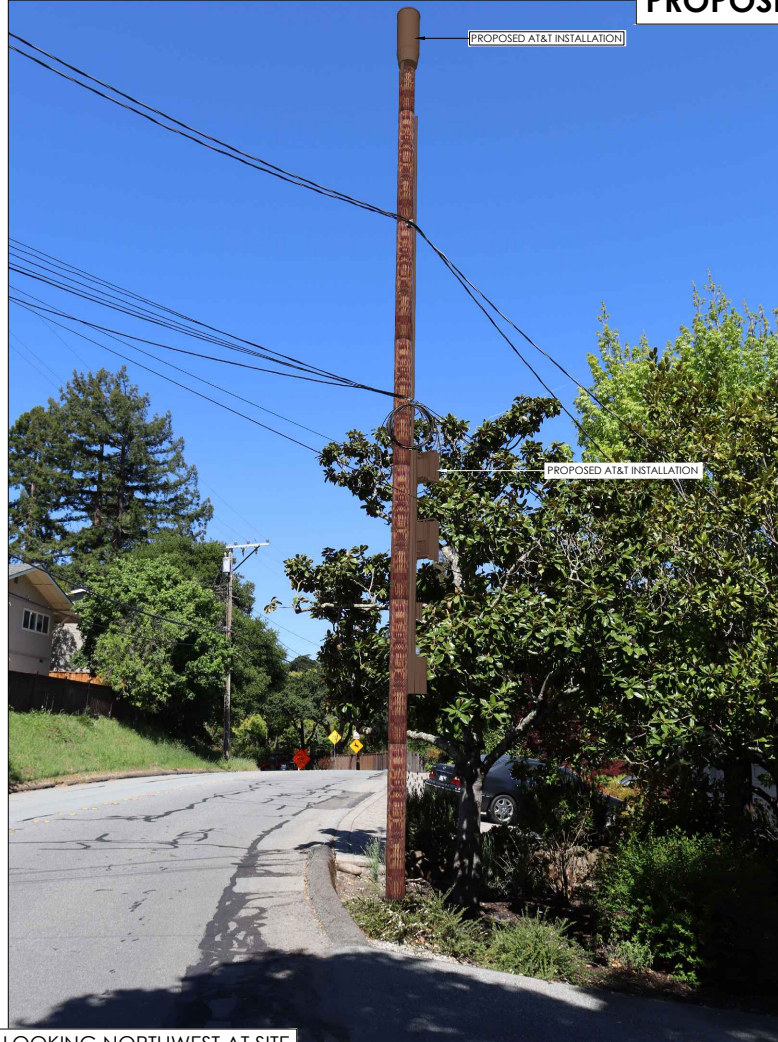

VIEW FROM CORDILLERAS RD LOOKING NORTHWEST AT SITE

CRAN_RSFR_PAPK1_05
NEAR 1888 CORDILLERAS RD
REDWOOD CITY, CA 94062

EXISTING



PROPOSED

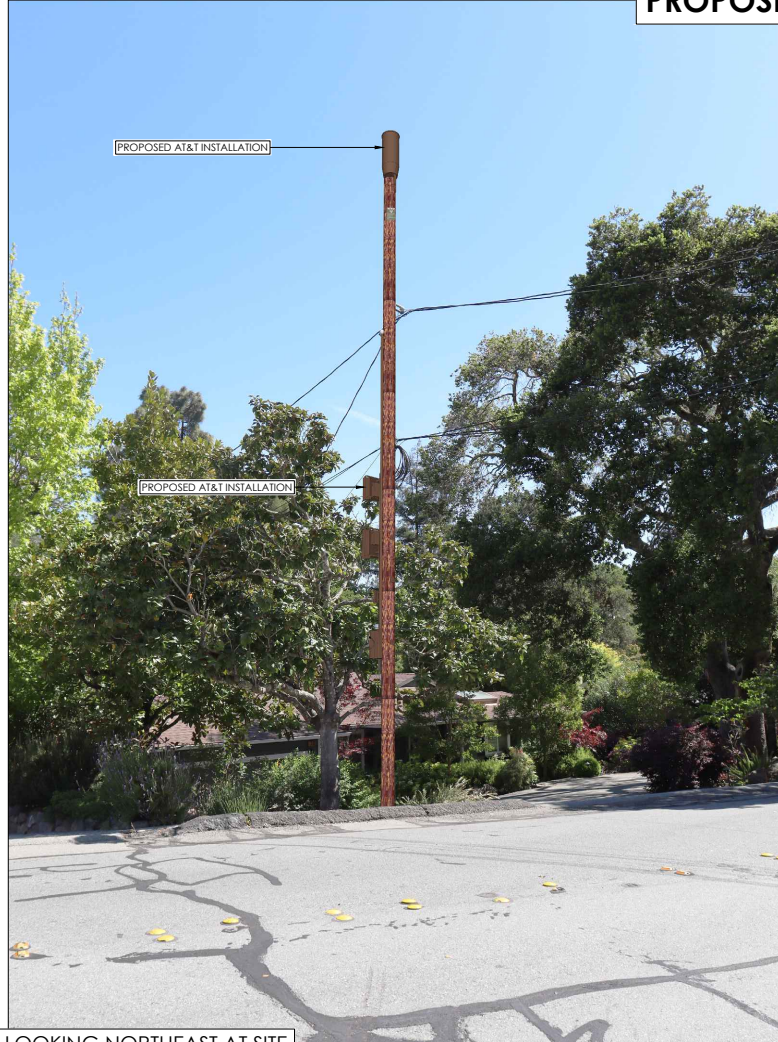

VIEW FROM CORDILLERAS RD LOOKING NORTHEAST AT SITE



COUNTY OF SAN MATEO - PLANNING AND BUILDING DEPARTMENT

ATTACHMENT F

ALTERNATIVE SITE ANALYSIS

CRAN_RSFR_PAPK1_05

PROW Near 1888 Cordilleras Rd, Emerald Hills, CA 94062

Site Type: PG&E Wood Distribution Pole in Public Right-of-Way

County: San Mateo

Applicant: AT&T Mobility

Prepared by: NextEdge Networks

Purpose & Methodology

Coverage Gap & Least Intrusive Means

AT&T has identified a significant gap in its wireless network coverage in the Emerald Hills / Cordilleras Road area of unincorporated San Mateo County. To close this gap, AT&T proposes installation of a small wireless facility on an existing PG&E wood distribution pole located in the public right-of-way.

This analysis demonstrates that the proposed site - Candidate A - represents the least intrusive means of closing the identified coverage gap. Each alternative pole location within the search ring was evaluated against PG&E's engineering standards governing third-party wireless attachments to its utility infrastructure. As documented herein, every alternative was eliminated due to conditions that render it ineligible under PG&E's mandatory safety requirements.

Governing Standards

PG&E Standard 027911 (Rev. #15)

Installation Details for Service to Pole-Mounted Communication Equipment - the base standard governing all wireless attachments to PG&E poles.

PG&E Standard 094675 (Rev. #00)

SmartPole Meter for Service to Pole-Mounted Communication Equipment - metering and service requirements.

CPUC General Order 95

Rules for Overhead Electric Line Construction - clearance, climbing space, and safety requirements for all utility pole attachments.

CANDIDATE A

Primary Candidate - Proposed Installation

PAPK1_05_A | PROW Near 1888 Cordilleras Rd, Emerald Hills, CA 94062 | 37.47325, -122.26635



Scope of Work & Site Design

Scope of Work

- Install (1) new 2-canister antenna on top of wooden PG&E utility pole
- Install (2) new Radio 4490 and Radio 4461 on wooden PG&E utility pole
- Install (2) new PSU ACDB on wooden PG&E utility pole
- Install (1) new coax conduit from equipment to new canister antenna
- Install (1) new power conduit from P.O.C. to equipment
- Install (1) new fiber conduit from P.O.C. to equipment
- Install (1) new equipment bracket
- Install (1) new SmartPole meter / disconnect
- Install (1) new fiber box
- All AT&T appurtenances painted non-glossy "Sable" (Sherwin Williams) to match pole color
- Existing wood utility pole to be replaced with new wood utility pole by PG&E

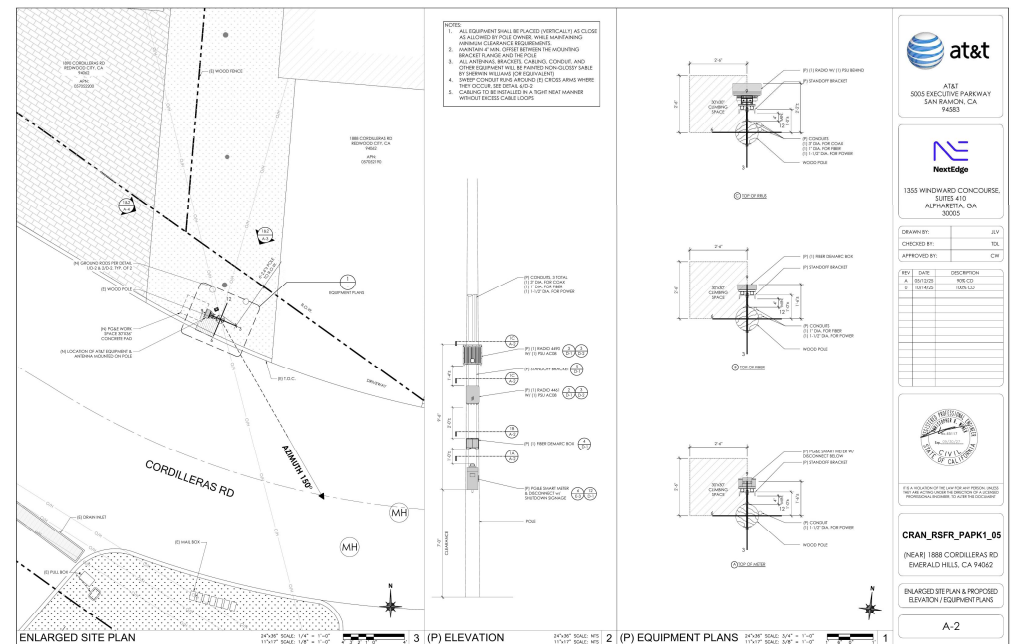

CANDIDATE B

ELIMINATED

PAPK1_05_B | PROW Near 1887 Cordilleras Rd, Emerald Hills, CA 94062 | 37.47319, -122.26634



Basis for Elimination

Distribution Equipment - Transformer

[PG&E Std. 027911, Section 5](#)

This pole carries a pole-mounted transformer connected to PG&E's primary voltage lines. Section 5 prohibits third-party antennas and communication equipment on any pole with PG&E distribution equipment connected to overhead primary lines.

Clearance Violation

[PG&E Std. 027911, Section 21](#)

This pole fails to provide the required 4-foot minimum clearance between PG&E equipment and non-PG&E obstructions.

CANDIDATE C

ELIMINATED

PAPK1_05_C | PROW Near 1895 Cordilleras Rd, Emerald Hills, CA 94062 | 37.47347, -122.26694



Google Earth - Edit Placemark

Basis for Elimination

Triangular Primary Framing

[PG&E Std. 027911, Section 6](#)

The primary voltage conductors on this pole are arranged at staggered heights in a triangular configuration rather than mounted on a single crossarm in flat construction. PG&E prohibits the design and installation of third-party antennas on pole tops where primary lines are built with triangular construction.

CANDIDATE D

ELIMINATED

PAPK1_05_D | PROW Near 1895 Cordilleras Rd, Emerald Hills, CA 94062 | 37.47344, -122.26680



Basis for Elimination

Clearance Violation - 4-Foot Minimum

[PG&E Std. 027911, Section 21](#)

This pole fails to provide the required 4-foot minimum clearance between PG&E poles or metering equipment and non-PG&E obstructions. The proximity of adjacent structures renders this pole ineligible for wireless attachment under PG&E's safety clearance requirements.

CANDIDATE E

ELIMINATED

PAPK1_05_E | PROW Near 1911 Cordilleras Rd, Emerald Hills, CA 94062 | 37.47343, -122.26686



Basis for Elimination

Distribution Equipment - Transformer

[PG&E Std. 027911, Section 5](#)

This pole carries a pole-mounted transformer connected to PG&E's primary voltage lines. Section 5 prohibits third-party antennas and communication equipment on any pole with PG&E distribution equipment connected to overhead primary lines. Distribution equipment includes transformers, primary risers, cutouts, fuses, switches, capacitors, and regulators.

CANDIDATE F

ELIMINATED

PAPK1_05_F | PROW Near 1870 Cordilleras Rd, Emerald Hills, CA 94062 | 37.47318, -122.26584



Basis for Elimination

Distribution Equipment - Cutouts

[PG&E Std. 027911, Section 5](#)

This pole carries cutouts connected to PG&E's primary voltage lines. Section 5 prohibits third-party antennas and communication equipment on any pole with PG&E distribution equipment connected to overhead primary lines. Distribution equipment includes transformers, primary risers, cutouts, fuses, switches, capacitors, and regulators.

CANDIDATE G

ELIMINATED

PAPK1_05_G | PROW Near 1840 Cordilleras Rd, Emerald Hills, CA 94062 | 37.47324, -122.26535



Basis for Elimination

Triangular Primary Framing

[PG&E Std. 027911, Section 6](#)

Primary voltage conductors are arranged in a triangular configuration at staggered heights. PG&E prohibits third-party antenna installations on poles with triangular framing construction.

Distribution Equipment - Transformer

[PG&E Std. 027911, Section 5](#)

This pole also carries a pole-mounted transformer connected to primary voltage lines, independently disqualifying it under Section 5.

CANDIDATE H

ELIMINATED

PAPK1_05_H | PROW Near 1823 Cordilleras Rd, Emerald Hills, CA 94062 | 37.47326, -122.26498



Basis for Elimination

Triangular Primary Framing

[PG&E Std. 027911, Section 6](#)

The primary voltage conductors on this pole are arranged at staggered heights in a triangular configuration rather than mounted on a single crossarm in flat construction. PG&E prohibits the design and installation of third-party antennas on pole tops where primary lines are built with triangular construction.

CANDIDATE I

ELIMINATED

PAPK1_05_I | PROW Near 1814 Cordilleras Rd, Emerald Hills, CA 94062 | 37.47330, -122.26460



Basis for Elimination

Distribution Equipment - Primary Riser

[PG&E Std. 027911, Section 5](#)

This pole carries a primary riser connected to PG&E's overhead primary voltage lines. Section 5 prohibits third-party antennas and communication equipment on any pole with PG&E distribution equipment connected to overhead primary lines. Distribution equipment includes transformers, primary risers, cutouts, fuses, switches, capacitors, and regulators.

Summary of Alternatives Evaluated

CRAN_RSFR_PAPK1_05 | PROW Near 1888 Cordilleras Rd, Emerald Hills, CA 94062

Candidate	Address	Coordinates	Status	Basis for Elimination
A	PROW Near 1888 Cordilleras Rd	37.47325, -122.26635	SELECTED	N/A - Meets all PG&E engineering standards
B	PROW Near 1887 Cordilleras Rd	37.47319, -122.26634	ELIMINATED	Transformer (\$5) + Clearance (\$21)
C	PROW Near 1895 Cordilleras Rd	37.47347, -122.26694	ELIMINATED	Triangular Framing (027911 \$6)
D	PROW Near 1895 Cordilleras Rd	37.47344, -122.26680	ELIMINATED	Clearance Violation - 4' Min. (027911 \$21)
E	PROW Near 1911 Cordilleras Rd	37.47343, -122.26686	ELIMINATED	Distribution Equipment - Transformer (027911 \$5)
F	PROW Near 1870 Cordilleras Rd	37.47318, -122.26584	ELIMINATED	Distribution Equipment - Cutouts (027911 \$5)
G	PROW Near 1840 Cordilleras Rd	37.47324, -122.26535	ELIMINATED	Triangular Framing (\$6) + Transformer (\$5)
H	PROW Near 1823 Cordilleras Rd	37.47326, -122.26498	ELIMINATED	Triangular Framing (027911 \$6)
I	PROW Near 1814 Cordilleras Rd	37.47330, -122.26460	ELIMINATED	Distribution Equipment - Primary Riser (027911 \$5)

Conclusion

AT&T evaluated eight (8) alternative PG&E wood distribution pole locations within the search ring for site CRAN_RSFR_PAPK1_05. Each alternative was assessed against PG&E's mandatory engineering standards for third-party wireless attachments (PG&E Standard 027911) and the California Public Utilities Commission's General Order 95.

Every alternative pole was eliminated due to one or more disqualifying conditions - including triangular primary framing configurations (027911, Section 6), the presence of distribution equipment connected to primary voltage lines (027911, Section 5), and clearance violations (027911, Section 21) - that are beyond AT&T's ability to modify or waive.

Candidate A, located in the PROW near 1888 Cordilleras Rd, is the only viable pole that satisfies all applicable PG&E engineering requirements and represents the least intrusive means of closing the identified coverage gap in AT&T's wireless network.



COUNTY OF SAN MATEO - PLANNING AND BUILDING DEPARTMENT

ATTACHMENT G

Owner/Licensee	Structure Type	Street Address	City	Lat (Decimal)	Lon (Decimal)	Distance to Nearest PAK1 (mi)	RF Engineering Collocation Analysis
PACIFIC BELL MOBILE SERVICES	POLE	CALIFORNIA WAY	REDWOOD CITY	37.456944	-122.272222	0.89	The Emerald Hills service area presents a uniquely challenging RF propagation environment - characterized by steep hillside terrain with elevation changes exceeding 200 feet, dense mature tree canopy, and closely spaced residential structures - that severely attenuates wireless signals and limits effective small cell coverage to approximately 500-1,000 feet from the antenna. These conditions require a small wireless facility precisely sited within the coverage gap itself, at an antenna height engineered to clear local obstructions while maintaining the concentrated, street-level coverage pattern necessary for reliable in-building service. This structure is located 4.699 ft from AT&T's target service area, outside the effective reach of a small wireless facility in this propagation environment. This location is technically non-viable to close AT&T's identified coverage gap.
GTE Mobinet of California Limited Partnership	POLE	938 Wilmington Way	Redwood City	37.454778	-122.265056	1.11	The Emerald Hills service area presents a uniquely challenging RF propagation environment - characterized by steep hillside terrain with elevation changes exceeding 200 feet, dense mature tree canopy, and closely spaced residential structures - that severely attenuates wireless signals and limits effective small cell coverage to approximately 500-1,000 feet from the antenna. These conditions require a small wireless facility precisely sited within the coverage gap itself, at an antenna height engineered to clear local obstructions while maintaining the concentrated, street-level coverage pattern necessary for reliable in-building service. This structure is located 1.1 miles (5,860 ft) from AT&T's target service area - well beyond the reach of any small wireless facility operating in this propagation environment. This location is technically non-viable to close AT&T's identified coverage gap.
T-Mobile West Corporation	TOWER	882 Heather Drive (SF13235A)	San Carlos	37.492028	-122.270972	1.29	The Emerald Hills service area presents a uniquely challenging RF propagation environment - characterized by steep hillside terrain with elevation changes exceeding 200 feet, dense mature tree canopy, and closely spaced residential structures - that severely attenuates wireless signals and limits effective small cell coverage to approximately 500-1,000 feet from the antenna. These conditions require a small wireless facility precisely sited within the coverage gap itself, at an antenna height engineered to clear local obstructions while maintaining the concentrated, street-level coverage pattern necessary for reliable in-building service. This structure is located 1.3 miles (6,811 ft) from AT&T's target service area - well beyond the reach of any small wireless facility operating in this propagation environment. Moreover, this macro tower's elevated mounting height would produce wide-area signal overshoot rather than the concentrated, street-level coverage pattern the terrain requires. This location is technically non-viable to close AT&T's identified coverage gap.
City of San Carlos	POLE	Highlands Park- Melendy Drive and Aberdeen Drive	San Carlos	37.495611	-122.27525	1.49	The Emerald Hills service area presents a uniquely challenging RF propagation environment - characterized by steep hillside terrain with elevation changes exceeding 200 feet, dense mature tree canopy, and closely spaced residential structures - that severely attenuates wireless signals and limits effective small cell coverage to approximately 500-1,000 feet from the antenna. These conditions require a small wireless facility precisely sited within the coverage gap itself, at an antenna height engineered to clear local obstructions while maintaining the concentrated, street-level coverage pattern necessary for reliable in-building service. This structure is located 1.5 miles (7,867 ft) from AT&T's target service area - well beyond the reach of any small wireless facility operating in this propagation environment. This location is technically non-viable to close AT&T's identified coverage gap.
T-Mobile West LLC	Building	1390 El Camino Real (SF23002B)	San Carlos	37.4975	-122.249278	1.92	The Emerald Hills service area presents a uniquely challenging RF propagation environment - characterized by steep hillside terrain with elevation changes exceeding 200 feet, dense mature tree canopy, and closely spaced residential structures - that severely attenuates wireless signals and limits effective small cell coverage to approximately 500-1,000 feet from the antenna. These conditions require a small wireless facility precisely sited within the coverage gap itself, at an antenna height engineered to clear local obstructions while maintaining the concentrated, street-level coverage pattern necessary for reliable in-building service. This structure is located 1.9 miles (10,137 ft) from AT&T's target service area - well beyond the reach of any small wireless facility operating in this propagation environment. Moreover, this building-mounted installation's height and orientation would produce a coverage geometry inconsistent with the street-level pattern the terrain requires. This location is technically non-viable to close AT&T's identified coverage gap.
Crown Castle GT Company, LLC	POLE	1030 WASHINGTON ST	SAN CARLOS	37.497722	-122.246361	2.01	The Emerald Hills service area presents a uniquely challenging RF propagation environment - characterized by steep hillside terrain with elevation changes exceeding 200 feet, dense mature tree canopy, and closely spaced residential structures - that severely attenuates wireless signals and limits effective small cell coverage to approximately 500-1,000 feet from the antenna. These conditions require a small wireless facility precisely sited within the coverage gap itself, at an antenna height engineered to clear local obstructions while maintaining the concentrated, street-level coverage pattern necessary for reliable in-building service. This structure is located 2.0 miles (10,612 ft) from AT&T's target service area - well beyond the reach of any small wireless facility operating in this propagation environment. This location is technically non-viable to close AT&T's identified coverage gap.
T-Mobile West Corporation	TANK	147 Highland Avenue (SF13056F)	San Carlos	37.505417	-122.272583	2.18	The Emerald Hills service area presents a uniquely challenging RF propagation environment - characterized by steep hillside terrain with elevation changes exceeding 200 feet, dense mature tree canopy, and closely spaced residential structures - that severely attenuates wireless signals and limits effective small cell coverage to approximately 500-1,000 feet from the antenna. These conditions require a small wireless facility precisely sited within the coverage gap itself, at an antenna height engineered to clear local obstructions while maintaining the concentrated, street-level coverage pattern necessary for reliable in-building service. This structure is located 2.2 miles (11,510 ft) from AT&T's target service area - well beyond the reach of any small wireless facility operating in this propagation environment. Moreover, this tank-mounted facility's elevation would produce omnidirectional wide-area coverage rather than the targeted street-level pattern the terrain requires. This location is technically non-viable to close AT&T's identified coverage gap.
T-Mobile West LLC	Building	1119 Industrial Rd. (SF03196A)	San Carlos	37.503611	-122.246778	2.36	The Emerald Hills service area presents a uniquely challenging RF propagation environment - characterized by steep hillside terrain with elevation changes exceeding 200 feet, dense mature tree canopy, and closely spaced residential structures - that severely attenuates wireless signals and limits effective small cell coverage to approximately 500-1,000 feet from the antenna. These conditions require a small wireless facility precisely sited within the coverage gap itself, at an antenna height engineered to clear local obstructions while maintaining the concentrated, street-level coverage pattern necessary for reliable in-building service. This structure is located 2.4 miles (12,460 ft) from AT&T's target service area - well beyond the reach of any small wireless facility operating in this propagation environment. Moreover, this building-mounted installation's height and orientation would produce a coverage geometry inconsistent with the street-level pattern the terrain requires. This location is technically non-viable to close AT&T's identified coverage gap.
T-Mobile West Corporation	TANK	224 Chestnut Street (SF13018D)	San Carlos	37.508944	-122.267806	2.47	The Emerald Hills service area presents a uniquely challenging RF propagation environment - characterized by steep hillside terrain with elevation changes exceeding 200 feet, dense mature tree canopy, and closely spaced residential structures - that severely attenuates wireless signals and limits effective small cell coverage to approximately 500-1,000 feet from the antenna. These conditions require a small wireless facility precisely sited within the coverage gap itself, at an antenna height engineered to clear local obstructions while maintaining the concentrated, street-level coverage pattern necessary for reliable in-building service. This structure is located 2.5 miles (13,041 ft) from AT&T's target service area - well beyond the reach of any small wireless facility operating in this propagation environment. Moreover, this tank-mounted facility's elevation would produce omnidirectional wide-area coverage rather than the targeted street-level pattern the terrain requires. This location is technically non-viable to close AT&T's identified coverage gap.
AT&T Mobility Spectrum LLC	POLE	260 Shelford Avenue (61121472 / Shelford Avenue)	San Carlos	37.510083	-122.27675	2.49	The Emerald Hills service area presents a uniquely challenging RF propagation environment - characterized by steep hillside terrain with elevation changes exceeding 200 feet, dense mature tree canopy, and closely spaced residential structures - that severely attenuates wireless signals and limits effective small cell coverage to approximately 500-1,000 feet from the antenna. These conditions require a small wireless facility precisely sited within the coverage gap itself, at an antenna height engineered to clear local obstructions while maintaining the concentrated, street-level coverage pattern necessary for reliable in-building service. This structure is located 2.5 miles (13,147 ft) from AT&T's target service area - well beyond the reach of any small wireless facility operating in this propagation environment. This location is technically non-viable to close AT&T's identified coverage gap.



COUNTY OF SAN MATEO - PLANNING AND BUILDING DEPARTMENT

ATTACHMENT H



Radio Frequency Emissions Compliance Report For AT&T Mobility

Site Name: CRAN_RSFR_PAPK1_05	Site Structure Type: Utility - Telephone Pole
Address: 1888 CORDILLERAS ROAD EMERALD HILLS, CA 94062	Latitude: 37.473252
Report Date: May 02, 2025	Longitude: -122.266346
	Project: CRAN

Compliance Statement

Based on information provided by AT&T Mobility and predictive modeling, the CRAN_RSFR_PAPK1_05 installation proposed by AT&T Mobility will be compliant with Radiofrequency Radiation Exposure Limits of 47 C.F.R. §§ 1.1307(b)(3) and 1.1310. RF alerting signage and restricting access to the antenna to authorized personnel that have completed RF safety training is required for Occupational environment compliance. The proposed operation will not expose members of the General Public to hazardous levels of RF energy at ground level or in adjacent buildings.

Certification

I, Tim Alexander, am the reviewer and approver of this report and am fully aware of and familiar with the Rules and Regulations of both the Federal Communications Commissions (FCC) and the Occupational Safety and Health Administration (OSHA) with regard to Human Exposure to Radio Frequency Radiation, specifically in accordance with FCC's OET Bulletin 65. I have reviewed this Radio Frequency Exposure Assessment report and believe it to be both true and accurate to the best of my knowledge.

General Summary

The compliance framework is derived from the Federal Communications Commission (FCC) Rules and Regulations for preventing human exposure in excess of the applicable Maximum Permissible Exposure ("MPE") limits. At any location at this site, the power density resulting from each transmitter may be expressed as a percentage of the frequency-specific limits and added to determine if 100% of the exposure limit has been exceeded. The FCC Rules define two tiers of permissible exposure differentiated by the situation in which the exposure takes place and/or the status of the individuals who are subject to exposure. General Population / Uncontrolled exposure limits apply to those situations in which persons may not be aware of the presence of electromagnetic energy, where exposure is not employment-related, or where persons cannot exercise control over their exposure. Occupational / Controlled exposure limits apply to situations in which persons are exposed as a consequence of their employment, have been made fully aware of the potential for exposure, and can exercise control over their exposure. Based on the criteria for these classifications, the FCC General Population limit is considered to be a level that is safe for continuous exposure time. The FCC General Population limit is 5 times more restrictive than the Occupational limits.



SIGNED, 29 MAY 2025

Table 1: FCC Limits

Frequency (MHz)	Limits for General Population/ Uncontrolled Exposure		Limits for Occupational/ Controlled Exposure	
	Power Density (mW/cm ²)	Averaging Time (minutes)	Power Density (mW/cm ²)	Averaging Time (minutes)
30-300	0.2	30	1	6
300-1500	f/1500	30	f/300	6
1500-100,000	1.0	30	5.0	6

f=Frequency (MHz)

In situations where the predicted MPE exceeds the General Population threshold in an accessible area as a result of emissions from multiple transmitters, FCC licensees that contribute greater than 5% of the aggregate MPE share responsibility for mitigation.

Based on the computational guidelines set forth in FCC OET Bulletin 65, Waterford Consultants, LLC has developed software to predict the overall Maximum Permissible Exposure possible at any location given the spatial orientation and operating parameters of multiple RF sources. The power density in the Far Field of an RF source is specified by OET-65 Equation 5 as follows:

$$S = \frac{EIRP}{4 \cdot \pi \cdot R^2} \text{ (mW/cm}^2\text{)}$$

Where EIRP is the Effective Radiated Power relative to an isotropic antenna and R is the distance between the antenna and point of study. Additionally, consideration is given to the manufacturers’ horizontal and vertical antenna patterns as well as radiation reflection. At any location, the predicted power density in the Far Field is the spatial average of points within a 0 to 6-foot vertical profile that a person would occupy. Near field power density is based on OET-65 Equation 20 stated as

$$S = \left(\frac{180}{\theta_{BW}} \right) \cdot \frac{100 \cdot P_{in}}{\pi \cdot R \cdot h} \text{ (mW/cm}^2\text{)}$$

Where P_{in} is the power input to the antenna, θ_{BW} is the horizontal pattern beamwidth and h is the aperture length.

Some antennas employ beamforming technology where RF energy allocated to each customer device is dynamically directed toward their location. In the analysis presented herein, predicted exposure levels are based on all beams at full utilization (i.e. full power) simultaneously focused in any direction. As this condition is unlikely to occur, the actual power density levels at ground and at adjacent structures are expected to be less than the levels reported below. These theoretical results represent maximum-case predictions as all RF emitters are assumed to be operating at 100% duty cycle.

For any area in excess of 100% General Population MPE, access controls with appropriate RF alerting signage must be put in place and maintained to restrict access to authorized personnel. Signage must be posted to be visible upon approach from any direction to provide notification of potential conditions within these areas. Subject to other site security requirements, occupational personnel should be trained in RF safety and equipped with personal protective equipment (e.g. RF personal monitor) designed for safe work in the vicinity of RF emitters. Controls such as physical barriers to entry imposed by locked doors, hatches and ladders or other access control mechanisms may be supplemented by alarms that alert the individual and notify site management of a breach in access control. Waterford Consultants, LLC recommends that any work activity in these designated areas or in front of any transmitting antennas be coordinated with all wireless tenants.

Analysis

- INSTALL (1) NEW 2' CANISTER ANTENNA ON TOP OF WOODEN PG&E UTILITY POLE
- INSTALL (2) NEW RADIO 4490 AND RADIO 4890 ON WOODEN PG&E UTILITY POLE

The antenna will be mounted on a 33' Wood Pole with centerlines 34.9' above ground level. Proposed antenna operating parameters are listed in Appendix A. Other appurtenances such as GPS antennas, RRUs and hybrid cable below the antennas are not sources of RF emissions. No other antennas are known to be operating in the vicinity of this site.



Figure 1: Antenna Locations

Power density decreases significantly with distance from any antenna. The panel-type antennas to be employed at this site are highly directional by design and the orientation in azimuth and mounting elevation, as documented, serves to reduce the potential to exceed MPE limits at any location other than directly in front of the antennas. For accessible areas at ground level, the maximum predicted power density level resulting from all AT&T Mobility operations is 0.97% of the FCC General Population limits. (Figure 1.2). The proposed operation will not expose members of the General Public to hazardous levels of RF energy at ground level or in adjacent buildings

On the pole in front of the antenna, predicted MPE levels will exceed the FCC General Population limits within 18 feet in front of the antennas and within 6 feet below the Antenna. The maximum predicted power density level resulting from all AT&T Mobility operations directly in front of the antennas is 3330.02% of the FCC General Population limits (666.004% of the FCC Occupational limits). Waterford Consultants, LLC recommends posting RF alerting signage (ACP Caution) on the pole visible upon approach that informs personnel accessing this area of basic precautions to be followed when working around antennas. This recommendation is depicted in Figure 2. Any work activity in front of transmitting antennas should be coordinated with AT&T Mobility.

The following plots show the cumulative spatial average predicted power density levels in the reference plane indicated as a percentage of the General Public Limits. Please note that 100% of the General Public Limits corresponds to 20% of the Occupational Limits.

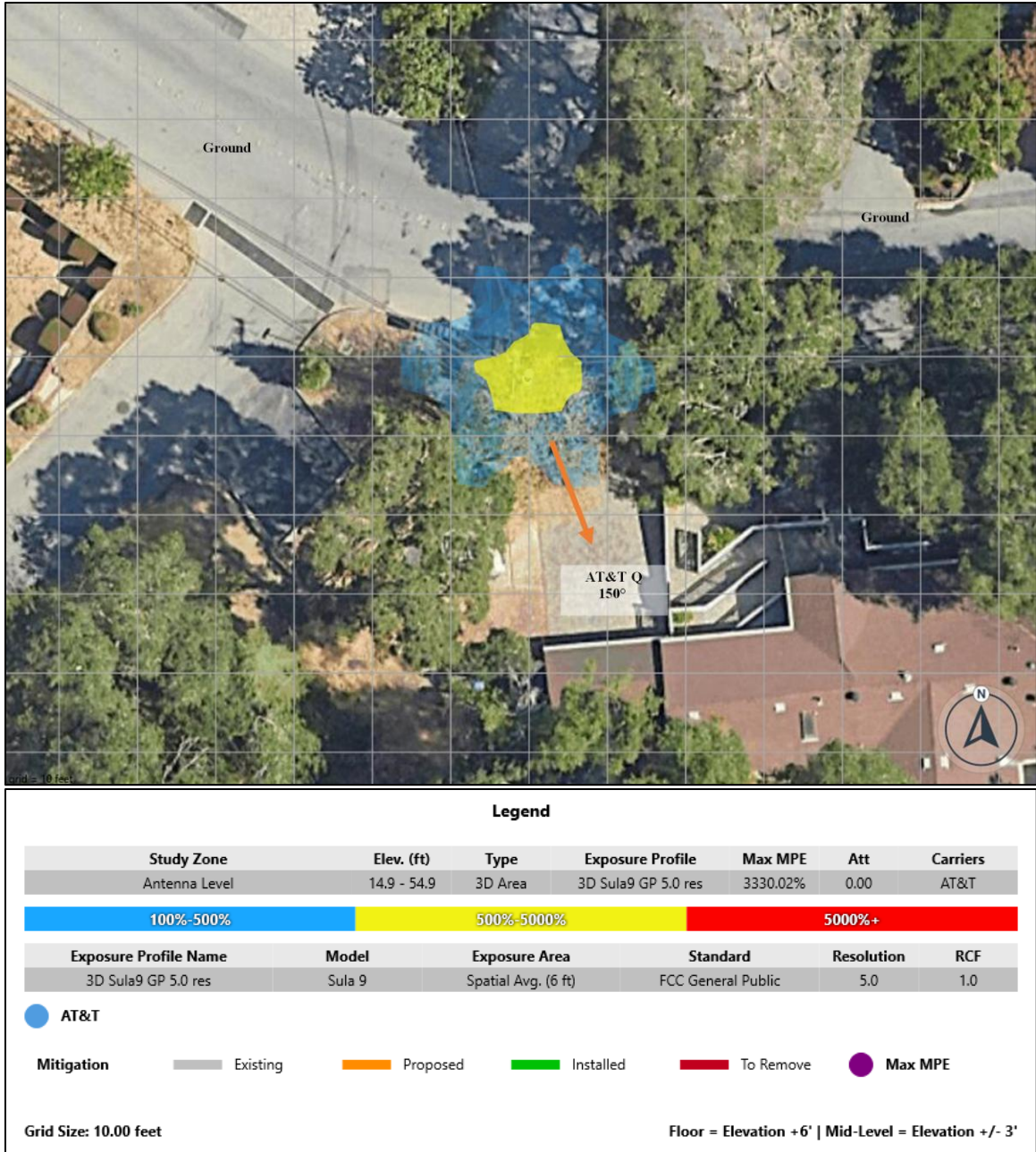
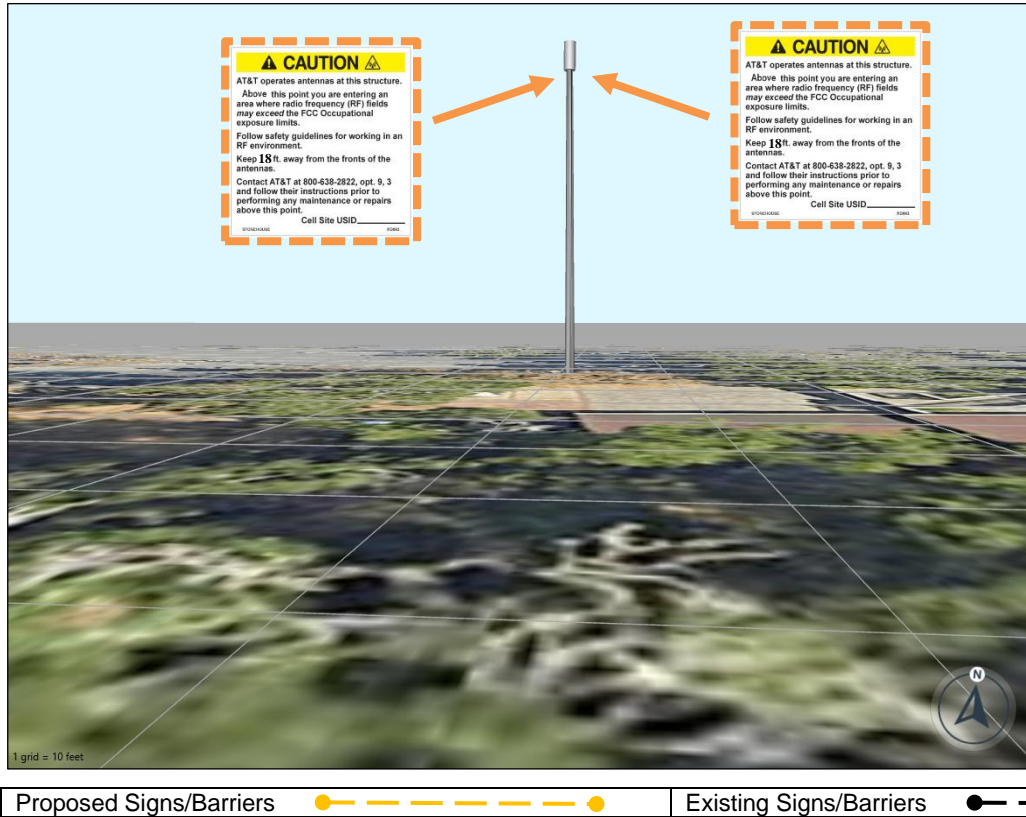

Figure1.1: Antenna Level

Compliance Requirement Diagram (Access Location)



Recommendations

AT&T Mobility Access Location
 Install (2) ACP Caution "Above" signs at 6ft below the antennas CL or 28ft AGL.

Signage may also be alternatively posted at ten (10) feet from base as per local market guidance.

Materials
 (2) ACP Caution "Above" signs sized 7"x7"

Safe Distance = 18ft
 Bottom Distance = 6ft

Figure 2: Mitigation Recommendations

Appendix A: Operating Parameters Considered in this Analysis

Ant #	Operator	Antenna Make	Antenna Model	Type	Block	Frequency (MHz)	Mech/Elec Az (deg)	Mech Downtilt (Deg)	Horizontal Beam Width (Deg)	Antenna Length (ft)	Antenna Gain (dBd)	TPO (Watts)	Total ERP (Watts)	Antenna Centerline Ground Level (0ft)	Bottom of Antenna Ground Level (0ft)
1	AT&T	GAMMANU	DOY9X360F16T4	Omni	B12A	700	150	0	197	2	3.15	240	495.69	34.9	33.9
1	AT&T	GAMMANU	DOY9X360F16T4	Omni	B5	850	150	0	224	2	4.01	240	604.24	34.9	33.9
1	AT&T	GAMMANU	DOY9X360F16T4	Omni	B77D	3700	150	0	193	2	4.78	160	480.97	34.9	33.9



COUNTY OF SAN MATEO - PLANNING AND BUILDING DEPARTMENT

ATTACHMENT I

**Small Cell Noise Assessment Letter
Prepared for: AT&T and Modus**

**FA Number: 16522536
Site Name: CRAN_RSFR_PAPK1_05
EBI Project Number: 051562-pr**

Address: (Near) 1888 Cordilleras Road Redwood City, California

June 2, 2025

1. Site Description:

Site CRAN_RSFR_PAPK1_05 / 16522536 involves the installation of one (1) antenna and three (3) remote radio units (RRUs) mounted on a pole, located in Redwood City, California, San Mateo County.

2. Purpose:

This letter provides calculated sound pressure levels from the proposed equipment when measured at the nearest property line from the proposed noise sources. Calculations were performed using site drawings dated May, 22 2025, information provided by Modus, and data from the equipment manufacturer, per the calculation methodology shown in Appendix A. Subsequent changes to the site design may yield changes in the projected post construction noise levels or compliance with applicable regulations and guidelines.

3. Regulatory Setting

County of San Mateo Noise Control Code of Ordinances § 4.88.320, Exterior Noise Standards.

1. The County of San Mateo outlines Exterior noise level limits in the Code of Ordinances § 4.88.320, Exterior Noise Standards. The maximum allowable noise level limits range from 50 to 75 dBA, based on use (residential, multi family, school, hospital, church and public library) and time of day (daytime or nighttime). The lowest noise level limit of 50 dBA for nighttime residential use has been applied to this analysis to simulate a worst-case scenario.

4. Relevant Proposed Equipment

The proposed site design includes a proposed Small Cell Wireless Facility in an existing right of way. Manufacturer specifications were reviewed for each of these units to assess the noise properties of each unit. Noise properties of the proposed equipment are described in Table 1.

The site design does not include installation of emergency back-up generators, equipment cabinets or other noise-generating equipment typically associated with traditional wireless telecommunications sites. The proposed installations will not utilize any external alarms.

The following Equipment is proposed for installation at this site:

Table 1 – Proposed Equipment				
Quantity	Description	Manufacturer	Model Number	Sound Pressure Level (dBA) @ 1 meter
1	Antenna	GAMMA NU	DOY9X360F16T4	none
1	RRU (passive cooling)	Ericsson	4461	36
2	RRU (passive cooling)	Ericsson	4490	26

Manufacturer acoustic data specifies a sound pressure or power level per each unit shown. See Appendix B.

Available specifications and product information were reviewed for the equipment listed in Table 1. Exclusions include measured ambient noise, existing equipment, fencing, walls, landscaping, topography, and property line setbacks.

5. *Calculated Sound Levels.*

Sound level propagation calculations were performed to determine the sound pressure level of the proposed equipment when measured at the distances referenced below. Equipment was assumed to be operating continuously 24-hours per day to simulate worst-case conditions. The sources and receiver were assumed to be at the same reference height to account for balconies, open windows and changes in elevation at adjacent properties. All calculations shown in Table 2 assume a free-field environment with no ground absorption, reflecting surfaces, barriers, or other obstructions. Actual results may vary due to field and environmental conditions.

Table 2 – Calculated Sound Pressure Level	
Equipment Sound Power from Table 1 (combined)	47.78 dB
Distance to Nearest Property Line is greater than	6.29 feet
Proposed Equipment Sound Level Contribution at Nearest Property Line	31.12 dBA
Lowest Applicable Noise Limit	50 dBA

6. *Statement of Compliance*

Based on the results of this analysis, and as presented in Table 2, EBI concludes that the noise produced from operation of the proposed equipment will comply with the Exterior Noise Standards described in the County of San Mateo Code of Ordinances § 4.88.320, Noise Control.

7. *Limitations*

This report was prepared for the use of Modus and AT&T. It was performed in accordance with generally accepted practices of other consultants undertaking similar studies at the same time and in the same locale under like circumstances. The conclusions provided by EBI are based solely on the information provided by the client. The observations in this report are valid on the date of the investigation. Calculations contained in this report should be considered accurate to within one decibel. Any additional information that becomes available concerning the site should be provided to EBI so that our conclusions may be revised and modified, if necessary. This report has been prepared in accordance with Standard Conditions for Engagement and authorized proposal, both of which are integral parts of this report. No other warranty, expressed or implied, is made.

Appendix A

Calculation Methodology

NOISE CALCULATION METHODOLOGY

All sounds originate from a source. The sound energy, produced by a source, creates variations in air pressure which travel in all directions much like a wave ripples across the water. The “loudness” or intensity of a sound is a function of the sound pressure level, defined as the ratio of two pressures: the measured sound pressure from the source divided by a reference pressure (i.e., threshold of human hearing). Sound level measurements are most commonly expressed using the decibel (dB) scale. The decibel scale is logarithmic to accommodate the wide range of sound intensities to which the human ear is capable of responding. On this scale, the threshold of human hearing is equal to 0 dB, while levels above 140 dB can cause immediate hearing damage.

One property of the decibel scale is that the combined sound pressure level of separate sound sources is not simply the sum of the contributing sources. For example, if the sound of one source of 70 dB is added to another source of 70 dB, the total is only 73 dB, not a doubling to 140 dB. In terms of human perception of sound, a 3 dB difference is the minimum perceptible change for broadband sounds (i.e., sounds that include all frequencies). A difference of 10 dB represents a perceived halving or doubling of loudness.

Environmental sound is commonly expressed in terms of the A-weighted sound level (dBA). The A-weighting is a standard filter to make measured sound levels more nearly approximate the frequency response of the human ear. Table 1 and Figure 1 show the adjustments made at each octave band frequency to contour un-weighted sound levels (dB) to A-weighted sound levels (dBA). This frequency response is defined in the American National Standards Institute Standard No. 5.1 and most other relevant standards related to measurement of noise levels.

Octave Band Center Frequency (Hz)	32	64	125	250	500	1000	2000	4000	8000	16000
A-weighting Adjustment (±dB)	-39.4	-26.2	-16.1	-8.6	-3.6	0.0	+1.2	+1.0	-1.1	-6.6

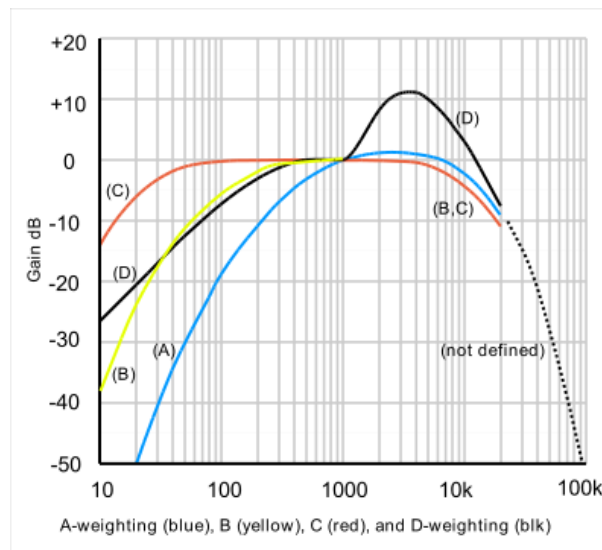

FIGURE 1 - WEIGHTED OCTAVE BAND ADJUSTMENTS (±dB)

Environmental sound varies depending on environmental conditions. Some sounds are sharp impulses lasting for short periods, while others rise and fall over longer periods. There are various measures (metrics) of sound pressure designed for different purposes. The Leq, or equivalent sound level, is the steady-state sound level over a period of time that has the same acoustic energy as the fluctuating sound that was measured over the same period. The Leq is commonly referred to as the average sound level and is calculated automatically by the sound level meter using methods defined in ANSI S1.4-1983¹.

Manufacturer-provided data for noise-generating equipment typically includes a measured sound pressure level (L_p), expressed in A-weighted decibels, taken at a specific distance from the equipment, known as a reference distance. For the purposes of this report, L_1 refers to the measured sound level, and r_1 refers to the reference distance from the source.

Sound varies inversely as the square of the distance from the source increases. This property of sound propagation is used to determine the sound levels at various distances from the source when L_1 and r_1 have been provided. In an unobstructed free-field environment, without any barriers or reflecting surfaces, sound pressure drops by 6 dBA with each doubling of distance. This relationship is expressed in the following equation:

$$L_2 = L_1 - |20 * \log\left(\frac{r_1}{r_2}\right)|$$

Where r_2 refers to the distance at distance 2 and L_2 refers to the sound level in dBA at distance 2.

When multiple sound sources are combined, the L_p values for each source must first be converted to sound power (L_w).

$$L_w = L_p + |10 * \log\left(\frac{Q}{4\pi * r^2}\right)|$$

In this report, EBI has assumed Q (directionality) is equal to 1 to represent full-sphere propagation.

The resultant L_w values are then added together, using logarithmic decibel addition, where L_{Σ} refers to the total level, and L_1, L_2 , etc. refer to the sound power of different individual sources.

$$L_{\Sigma} = 10 * \log_{10} \left(10^{\frac{L_1}{10}} + 10^{\frac{L_2}{10}} + \dots + 10^{\frac{L_n}{10}} \right) dB$$

¹ American National Standards Institute, ANSI S1-4-1983, American National Standard Specification for Sound Level Meters, 1983

Appendix B

Excerpts from Equipment Specifications

Description 329/1551-LZA 701 6001/1 Uen AE

Radio Description

Radio 4490HP

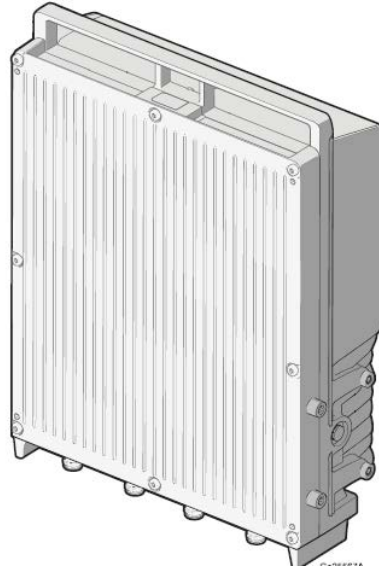

Acoustic Noise

With the fan, the acoustic noise is ambient temperature dependent, as listed below.

Table 11 Total Sound Power Level for Radio 4490HP with Fan

Temperature (°C)	Sound Power in Bel (A) ⁽¹⁾
+15	3.3
+20	3.7
+25	4
+30	4.5
+35	5
+40	5.5
+45	6.1
+55	7.4

(1) The total sound power level radiated by Radio 4490HP measured in accordance with ISO 9614-2.

Table 12 Maximum Sound Pressure Level for Radio 4490HP with Fan

Temperature (°C)	Sound Pressure (dBA) ⁽²⁾					
	Front	Back	Left from the Front	Right from the Front	Top	Bottom
15	16	20	16	17	16	19
20	20	25	20	20	19	23
25	23	29	24	24	24	25
30	28	33	30	30	29	29
40	38	43	39	39	39	39
45	44	48	46	46	46	44
55	57	60	58	58	58	59

(2) Sound pressure (spherical) at busy hour at 1-meter distance in accordance with ISO 11203 or ISO 9614-2.

Description 351/1551-LZA 701 6001/1 Uen K

Radio Description

Radio 4890HP



Acoustic Noise

The Radio 4890HP sound pressure level is lower than 28 dBA at 1-meter distance for hemispherical distribution, based on ISO 9614-2 and ISO 11203.

With the fan, the acoustic noise is ambient temperature dependent, as listed below.

Table 14 Maximum Sound Pressure Level (dBA) for Radio 4890HP with Fan 15

Temperature (°C)	Radio 4890HP Sound Pressure Level (dBA) at 1-meter Distance ⁽¹⁾
+10	52
+15	52
+20	52
+25	55.5
+30	57.5
+40	63
+45	64.5
+55	73.5

⁽¹⁾ The sound pressure level is measured at hemispherical distribution.

Radio Description

Radio 4467

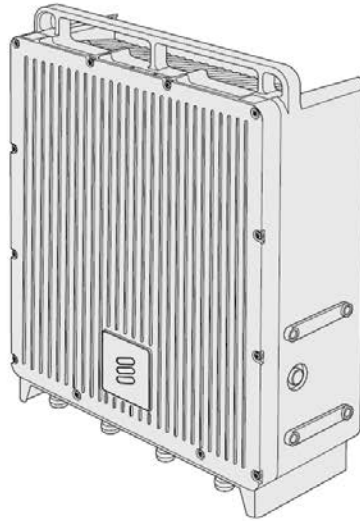

Acoustic Noise

Radio 4467 sound pressure level is lower than 28 dBA at 1-meter distance for hemispherical distribution, based on ISO 9614-2 and ISO 11203.

With the fan, the acoustic noise is ambient temperature dependent, as listed below.

Table 6 Maximum Sound Pressure Level (dBA) for Radio 4467 with Fan

Temperature (°C)	Radio 4467 Sound Pressure Level (dBA) at 1-meter Distance ⁽¹⁾	
	Products other than Radio 4467 44B77D 44B77G C	Radio 4467 44B77D 44B77G C
+10	34	38
+15	34	38
+20	34	38

Temperature (°C)	Radio 4467 Sound Pressure Level (dBA) at 1-meter Distance ⁽¹⁾	
	Products other than Radio 4467 44B77D 44B77G C	Radio 4467 44B77D 44B77G C
+25	34	38
+30	34	42
+40	34	47
+45	36.5	49
+55	43.5	53

⁽¹⁾ The sound pressure level is measured at hemispherical distribution.

Appendix C

Certification

CERTIFICATION

This report has been reviewed and approved by:



sealed 02jun2025

Michael McGuire PE
Professional Electrical Engineer
California License# E18898
mike@h2dc.com

Note that EBI's scope of work is limited to an evaluation of the Sound Properties of the equipment noted in this report. The engineering and design of the building and related structures, as well as the impact of the antennas and broadcast equipment on the structural integrity of the building, are specifically excluded from EBI's scope of work.