

FIRE MARSHAL'S OFFICE



San Mateo County Fire Department

FIRE CHIEF
JED WILSON

ASSISTANT CHIEF
RYAN WEST

FIRE MARSHAL
PATRICK GRIFFIN

DEPUTY FIRE MARSHALS
JOHN RIDDELL
AUSTIN SEELY
CLINTON DYER
TYLER STURM
JORDAN MOTTA
SHANE MCDONAGH

320 Paul Scannell Drive, San Mateo, California 94402 (650) 573-3846 SMCFDfiremarshal@fire.ca.gov

Standard Detail and Specification Manual

Section: Response	Title: Roads and Turn-Arounds
Effective: January 1, 2026	Revised: November 30, 2025
Number: CFS-07	Authorized By: Patrick Griffin, Fire Marshal

PURPOSE:

This standard establishes the minimum requirements necessary to provide safe and adequate access for emergency equipment, civilian evacuation, and to allow unobstructed traffic circulation during an emergency. The provisions of this regulation shall apply to new and existing roadways or driveways, which are extended, reconstructed, or improved pursuant to a new development approval. Fire department emergency access shall be provided when new structures or buildings are constructed, and for existing structures where the San Mateo County Building Regulations requires the entire structure or building to conform to the requirements for new structures or buildings.

CODE REFERENCES:

- 2025 California Fire Code, Chapter 5
- 2025 California Fire Code, Appendix D

FIRE DEPARTMENT EMERGENCY ACCESS:

Fire department emergency access is to be provided to within 150 ft of all portions of the facility and all portions of the exterior walls of the first story of the buildings as measured by an approved access route around the exterior of the building or facility.

DIMENSIONS:

- All new emergency access roads shall have 15 ½ feet of vertical clearance and have an unobstructed minimum width of 20 feet.
- Where hydrants are located, the road shall be a minimum of 26 feet wide for a length of 20 feet on each side of the hydrant (40 feet total length).

SURFACE:

- Emergency access roads shall be designed and maintained to support the imposed load of a fire apparatus weighing at least 75,000 lbs. and shall have a surface providing all-weather driving capabilities. Certification by a civil engineer may be required.

- Grades of less than 15% shall be surfaced with a minimum Class 2 aggregate base or equivalent with 95% compaction. Asphalt or concrete is preferred.
- Grades of 15% to 20% shall require a non-skid asphalt or grooved concrete surface, or equivalent.
- Grades 15% to 20% shall be limited to 150 ft. in length.

TURNING RADIUS:

The centerline turning radius for emergency apparatus access roads shall be 35 feet.

TURNAROUNDS:

- Dead-end emergency access exceeding 150 ft shall be provided with width and turnaround provisions meeting California Fire Code Appendix D.
- Turnarounds shall have a maximum longitudinal slope no greater than eight percent (8%). The longitudinal slope is defined as the slope corresponding to the long axis of a vehicle as it travels into, out of, and through a turnaround. This slope shall be maintained beginning at and ending at the point of tangency of the edge of pavement curves for the turnaround. The cross-slope perpendicular to the longitudinal slope shall not exceed five percent (5%).

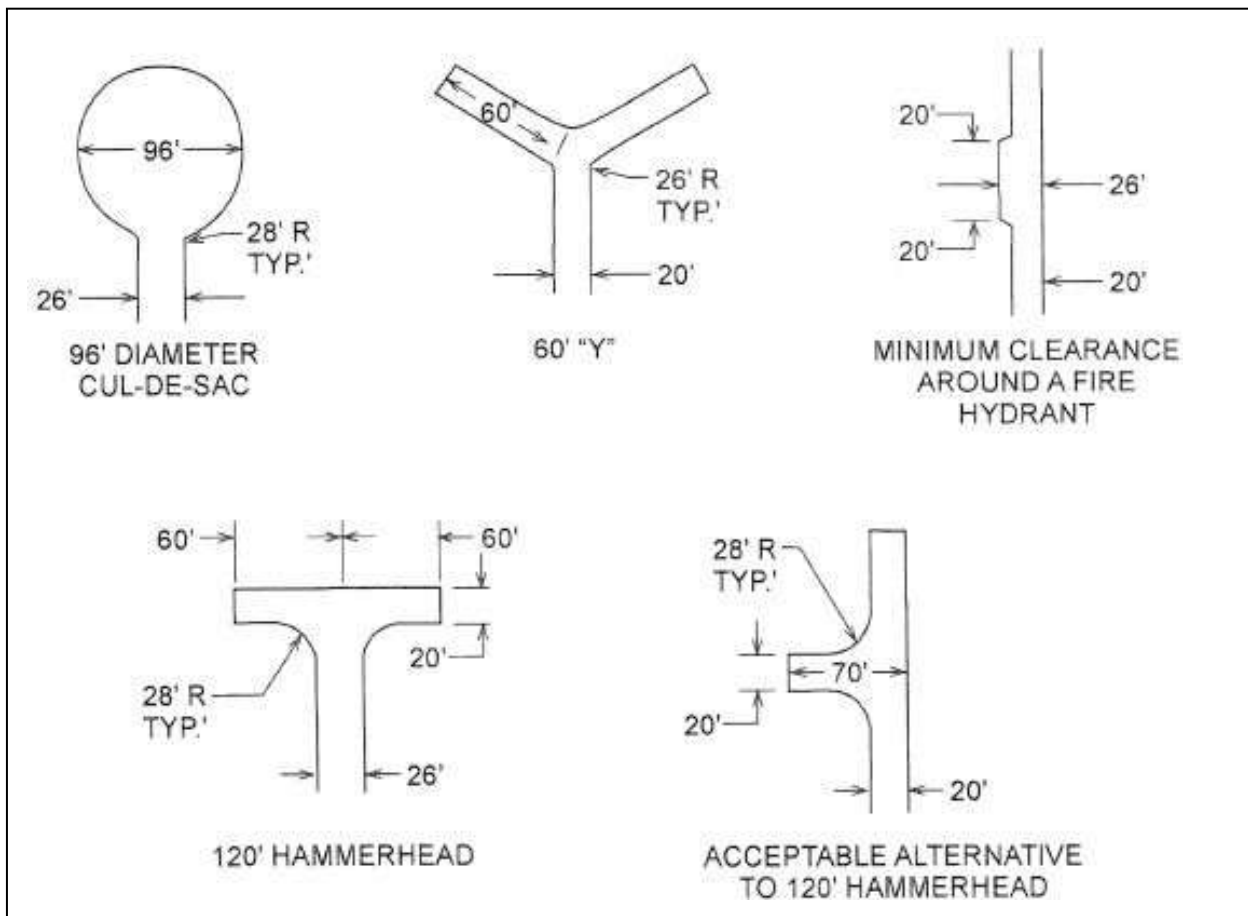

ROAD GRADE:

- Road grades shall not exceed 15% without the approval of the Fire Marshal. (See surface requirements above.)
- Road grades shall not exceed 20%.
- Grades 15% to 20% shall be limited to 150 ft. in length.

PARKING:

Parking on emergency access roads shall be as follows:

- 20-26 feet road width – no parking on either side of the roadway.
- More than 26 feet and up to 32 feet – parking is allowed on only one side of roadway.
- More than 32 feet in width – parking is not restricted.
- Turnaround bulbs – no parking is allowed in bulb if diameter is less than 96 feet.
- The posting of no parking signs may be required on roadways where parking is restricted.

BRIDGES:

When a bridge is used as a part of emergency access, it shall be constructed and maintained in accordance with HS20-44 Highway Loading. The bridge shall be designed for a live load sufficient to carry the imposed loads of fire apparatus as stated herein:

- Weight: Every private bridge hereafter constructed or re-constructed due to damage, deterioration, or obsolescence shall be designed to support an imposed load of fire apparatus weighing at least 75,000 lbs. Vehicle loads shall be posted and dated at both entrances to bridges. (HS20-44 Highway loading)
- Height: A minimum clear vertical clearance of 13 ½ feet as measured from the driving surface of the bridge shall be provided. In situations where a grade change occurs which might require a greater vertical clearance, such additional clearance shall be determined on a case-by-case basis by the Fire Marshal.
- Width: All bridges must be a minimum of 20 feet clear width. The Fire Marshal may allow the width to be reduced for a bridge providing access to R-3 or U occupancies. One-way bridges, and bridges with less than 20' of clear width, require a turnout at both ends of the bridge.
- Certification: Every private bridge providing fire apparatus access hereinafter constructed or re-constructed shall be engineered by a licensed civil or structural engineer and approved by the Fire Marshal. Certification that the bridge complies with the design standards required in sub-section of this section must be provided by the design engineer, to the Fire Marshal.
- Re-certification: Every private bridge shall be re-certified every ten (10) years or whenever deemed necessary by the Fire Marshal.

GATES:

- Gates shall be a minimum of 2 feet wider than the roadway they serve.
- Overhead gate structures shall have a minimum of 15 ½ feet of vertical clearance.
- Locked gates shall be provided with a Knox Box or Knox Padlock for fire department access.
- Electric gates shall be provided with a Knox Gate Switch and automatically open during power failures unless equipped with manual override capability (when authorized by San Mateo County Fire Department).
- Gates providing fire access to a driveway or other roadway shall be located at least 35 feet from the primary road or street and shall open to allow a vehicle to stop without obstructing traffic on the adjoining roadway.