

County of San Mateo

Sanitary Sewer Standard Details and Specifications

- C-1 Sanitary Sewer Manhole Detail
- C-2 Sanitary Sewer Manhole Covers and Frames
- C-3 Standard Sewer Cleanout Detail
- C-4 Sanitary Sewer Flushing Inlet Detail
- C-5 Sewer Lateral Detail
- C-6 Standard Trench Backfill and Bedding Detail for Vitrified Clay and Ductile Iron Sewer Pipe
- C-7 Standard Trench Backfill and Bedding Detail for Polyvinyl Chloride Sewer Pipe
- C-8 Lateral Connection Installation Detail on Existing Pipe
- C-9 Overflow and Backflow Device Detail
- C-10 Vitrified Clay and Ductile Iron Sewer Pipe Crossing Repair
- C-11 Polyvinyl Chloride Sewer Pipe Crossing Repair
- C-12 Concrete Encasement Detail
- C-13 Standard Specifications - General Notes
- C-14 Standard Specifications - Pipe and Fittings
- C-15 Standard Specifications - Testing Requirements (1 of 2)
- C-16 Standard Specifications - Testing Requirements (2 of 2)

COUNTY OF SAN MATEO
DEPARTMENT OF
PUBLIC WORKS

REDWOOD CITY
CALIFORNIA

DRAWN BY: T.D.
CHECK BY: M.C.
APPROVED BY: A.M.S

SCALE: NONE
DATE: 6/2015
REVISED: 04/2024

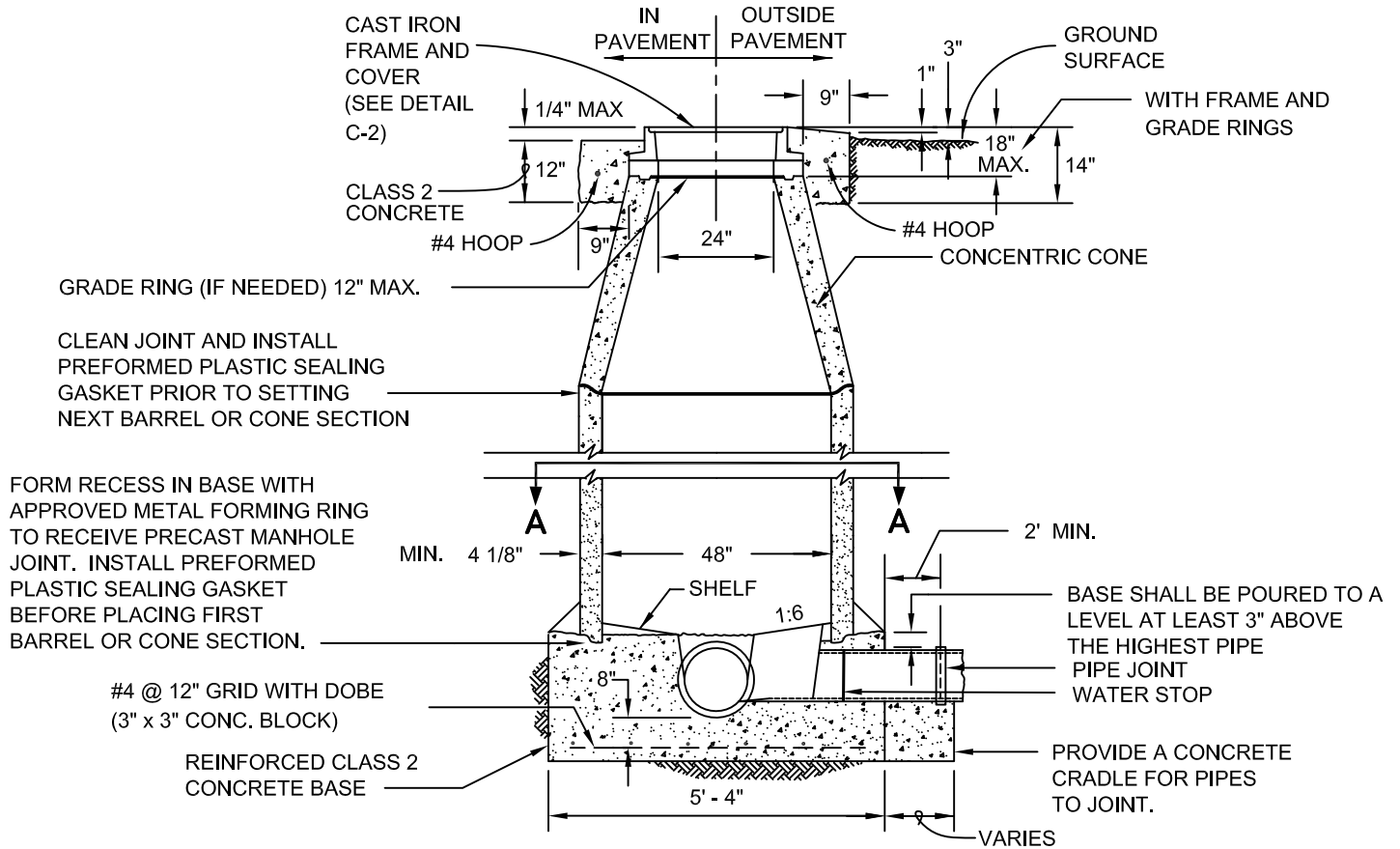

NOTES:

1. ALL STEEL TO BE 3" CLEAR.
2. MANHOLE SHELF SHALL BE MORTARED TO A SLOPE OF 1:6.
3. THERE SHALL BE NO STEPS IN THE MANHOLE.
4. PREFORMED PLASTIC SEALING GASKET SHALL BE "RAM-NEK" OR APPROVED EQUAL.
5. STANDARD WATER STOPS SHALL BE INCORPORATED INTO THE MANHOLE BASE WHEN PVC PIPES ARE USED.
6. MANHOLE THROAT LOCATION TO BE OPPOSITE THE LARGEST SHELF AREA OR AS DIRECTED BY THE ENGINEER.
7. NO LATERAL CONNECTIONS TO HDPE MANHOLE.
8. ANY VARIATION FROM DETAIL SHALL BE APPROVED BY THE ENGINEER.

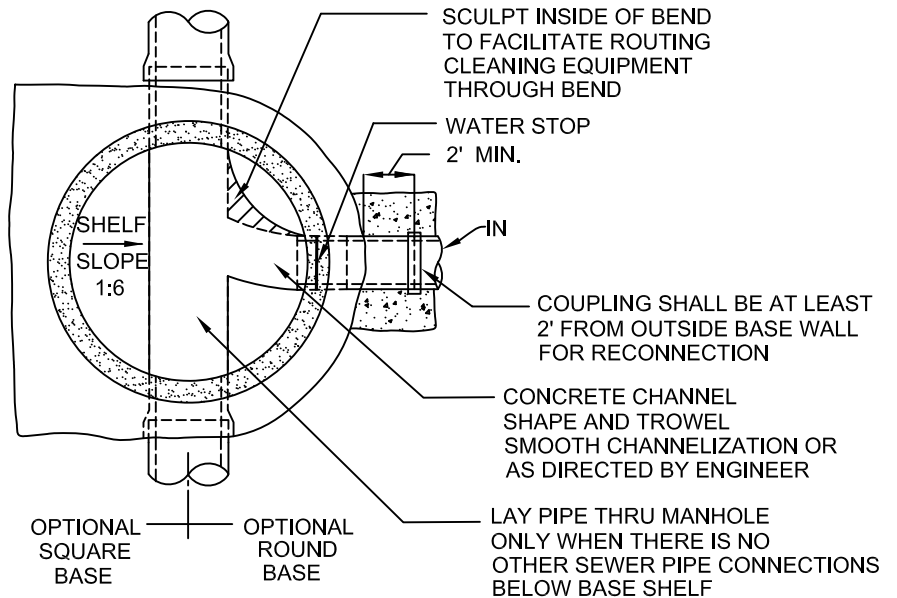

SECTION A-A

SANITARY SEWER MANHOLE DETAIL

SAN MATEO COUNTY DEPARTMENT
OF
PUBLIC WORKS
.....
REDWOOD CITY
CALIFORNIA

DRAWN BY: M.L.
CHECK BY: R.O.
APPROVED BY: N.R.C.

SCALE: NONE
DATE: 6/95
REVISED:

GENERAL NOTE:

FRAME AND COVER SHALL MEET OR EXCEED THE REQUIREMENTS OF AASHTO H-20 LOADING.

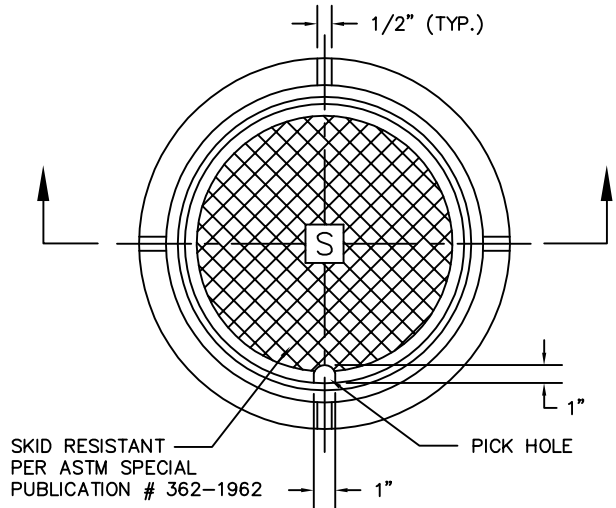
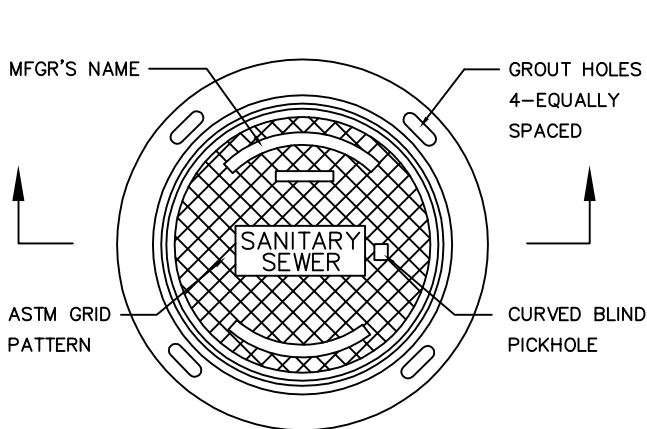

* ALL MATERIALS USED SHALL CONFORM TO ASTM SPEC. A-159-70T-G3000 OR U.S. GOV'T SPEC. QQ1-653

* ALL MATERIALS USED SHALL CONFORM TO ASTM SPEC. A-159-64T-G3000 OR U.S. GOV'T SPEC. QQ1-653

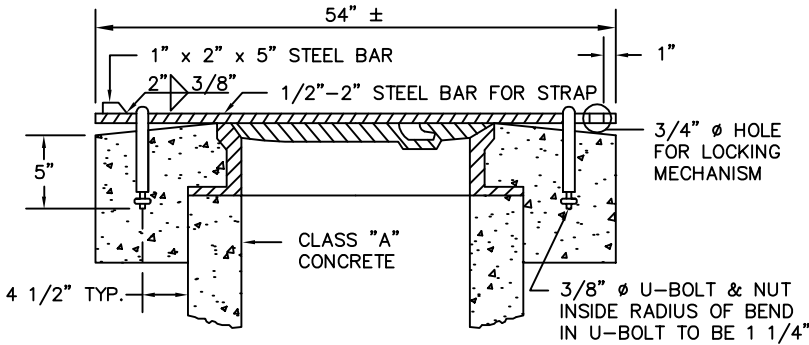
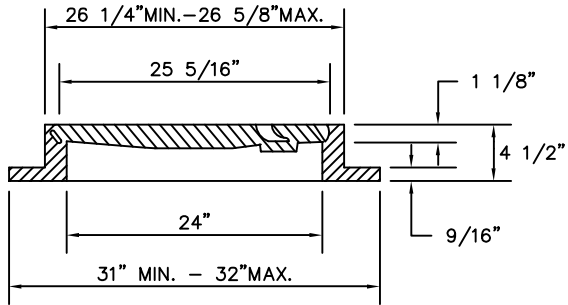

- * MANHOLE STRAP TO BE USED IN OFF ROAD AREA WHERE SPECIFIED BY THE ENGINEER
- * U-BOLTS, NUT & STRAP SHALL BE HOT DIP GALVANIZED AFTER FABRICATION

SECTION

**SANITARY SEWER
MANHOLE COVER, FRAME
AND STRAP DETAIL**

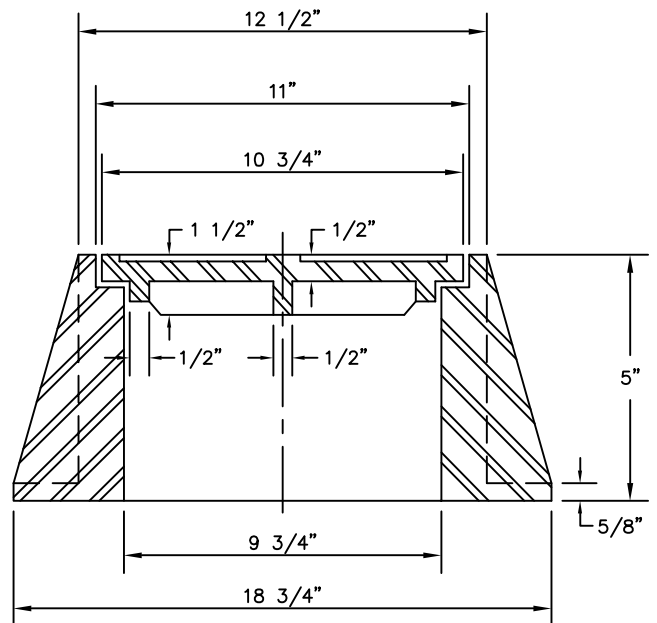

SECTION

**SANITARY SEWER
FLUSHING INLET
COVER**

SAN MATEO COUNTY DEPARTMENT
OF
PUBLIC WORKS

REDWOOD CITY
CALIFORNIA

DRAWN BY: N.M.
CHECK BY: A.M.S.
APPROVED BY: N.R.C.

SCALE: NONE
DATE: 8/06
REVISED:

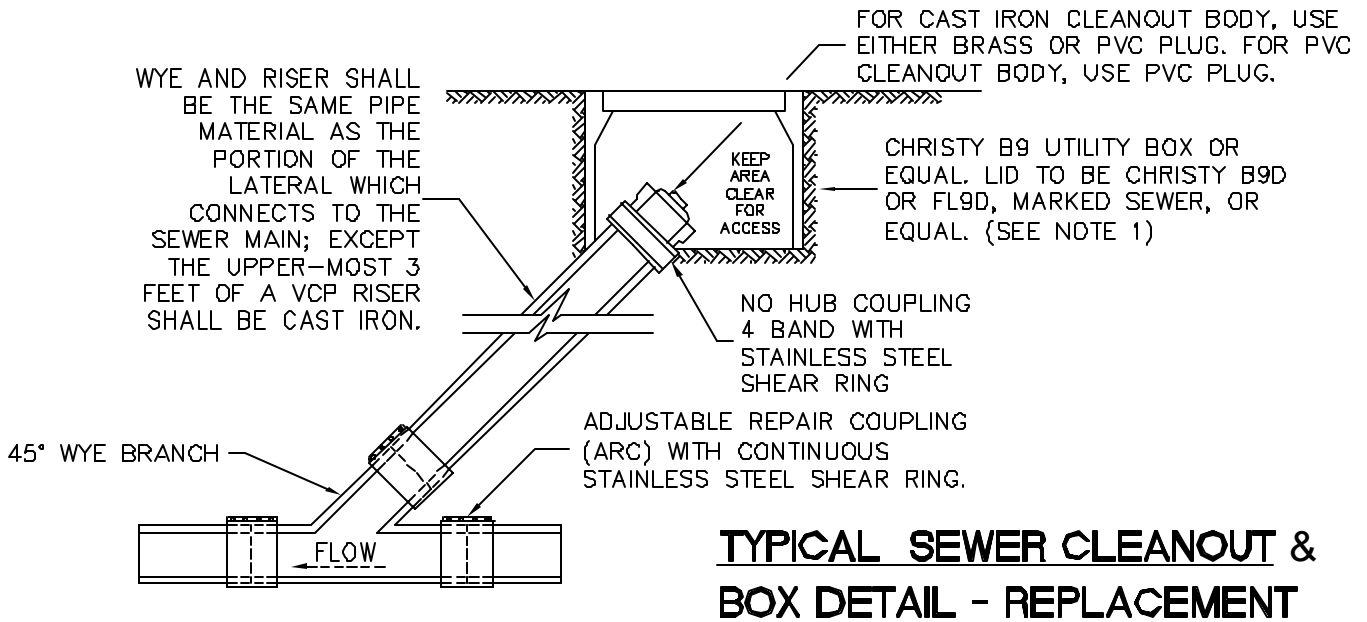
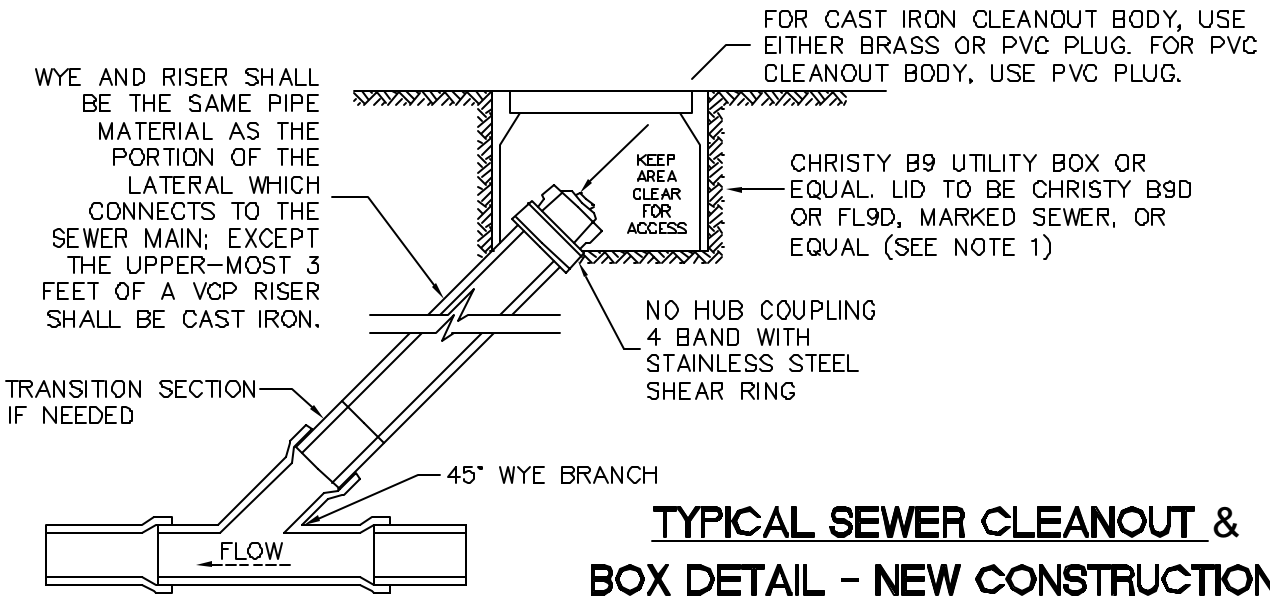

NOTES:

1. WHEN BOX IS SUBJECT TO TRAFFIC LOADING, PROVIDE CAST IRON LID.
2. BOX TO BE PLACED SUCH THAT CLEANOUT CAP CAN BE EASILY REMOVED, SEE ILLUSTRATION.
3. PROPERTY OWNER IS RESPONSIBLE FOR MAINTAINING LATERAL FROM THE PROPERTY STRUCTURE TO DISTRICT MAIN. DISTRICT PROVIDES COURTESY SERVICE FROM DISTRICT STANDARD PROPERTY LINE CLEANOUT TO THE MAIN.
4. SDR-26 WYE, RISER, CLEANOUT BODY AND CAP CAN BE USED ONLY WHEN LATERAL FROM PROPERTY LINE TO MAIN LINE IS REPLACED WITH SDR-26.
5. WHEN ENTIRE LATERAL IS REPLACED, LATERAL FROM PROPERTY LINE CLEANOUT TO MAIN LINE SHALL HAVE A 14-1-UF GAUGE MINIMUM SINGLE CONDUCTOR TRACER WIRE TAPED TO THE ENTIRE LENGTH OF THE PIPE.

CONSTRUCTION OF A STANDARD CLEANOUT REQUIRES MULTIPLE INSPECTIONS BY DISTRICT PERSONEL:

1. FIRST INSPECTION - TO INSPECT WYE AND RISER, WYE AND RISER MUST BE EXPOSED.
2. SECOND INSPECTION - TO INSPECT PLACEMENT OF BOX, LID AND LOCATION OF CLEANOUT WITHIN BOX .

SAN MATEO COUNTY DEPARTMENT
OF
PUBLIC WORKS
.....
REDWOOD CITY
CALIFORNIA

DRAWN BY: N.M.A.
CHECK BY: R.O.
APPROVED BY: N.R.C.

SCALE: NONE
DATE: 6/95
REVISED:

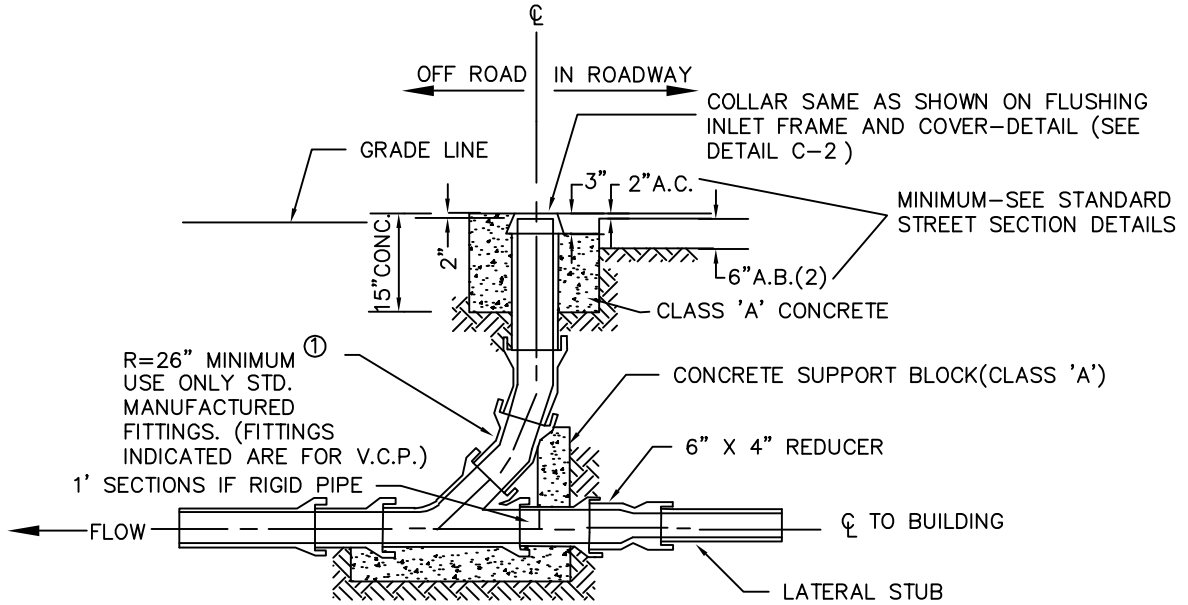

FLUSHING INLET WITH LATERAL STUB

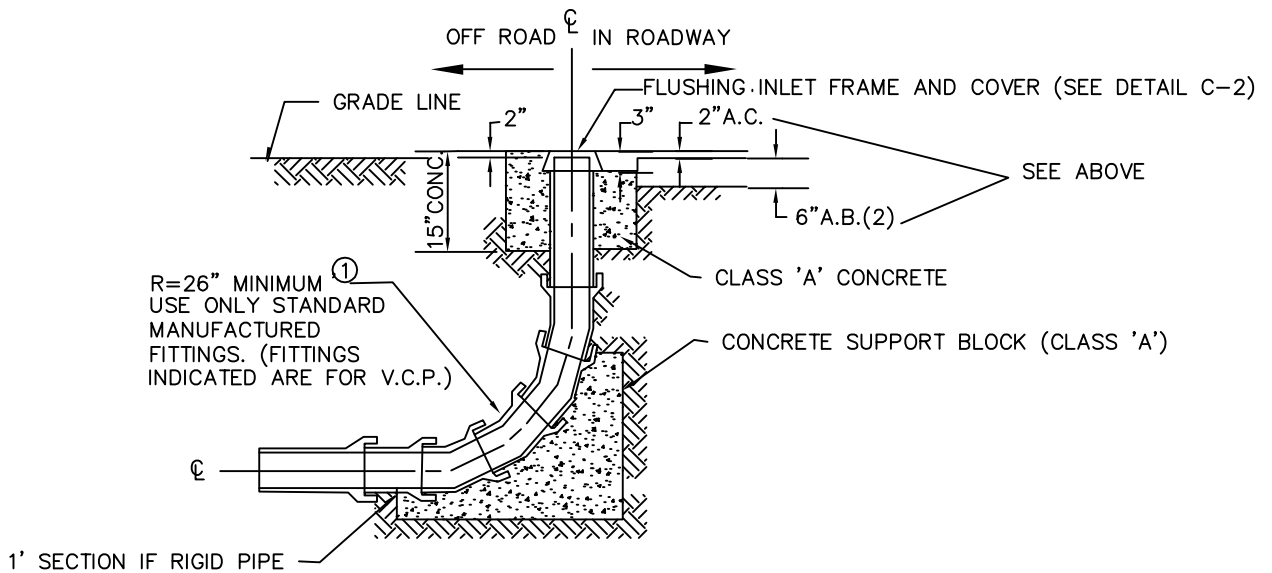

NOTE: ① FOR P.V.C. PIPE, LARGE 90° MANUFACTURED SWEEPS MAY BE USED IF R=36" OR GREATER

FLUSHING INLET

SANITARY SEWER FLUSHING INLET DETAIL

SAN MATEO COUNTY DEPARTMENT
OF
PUBLIC WORKS
.....
REDWOOD CITY
CALIFORNIA

DRAWN BY: N.M.A.
CHECK BY: R.O.
APPROVED BY: N.R.C.

SCALE: NONE
DATE: 6/95
REVISED: _____

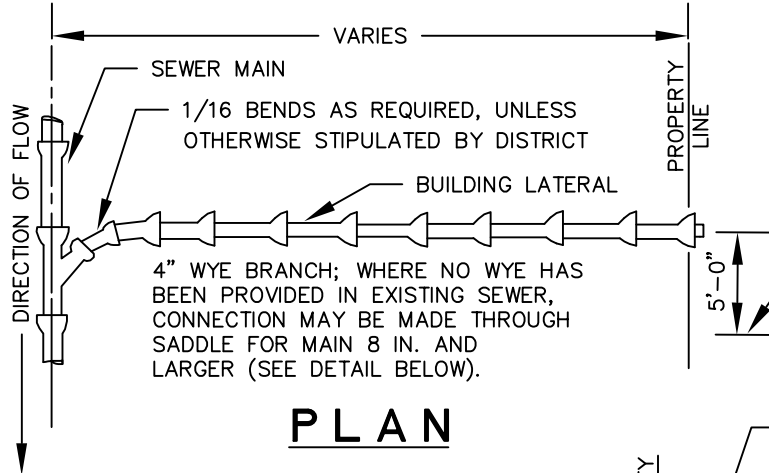

ON NEW CONSTRUCTION—LATERAL TO BE PLACED 5' ABOVE LOWER LOT LINE UNLESS OTHERWISE DIRECTED BY THE ENGINEER. THE WYE LATERAL AND PROPERTY LINE CLEAN OUT SHALL BE OF THE SAME MATERIAL

LOWER LOT LINE IN RELATION TO SEWER FLOW

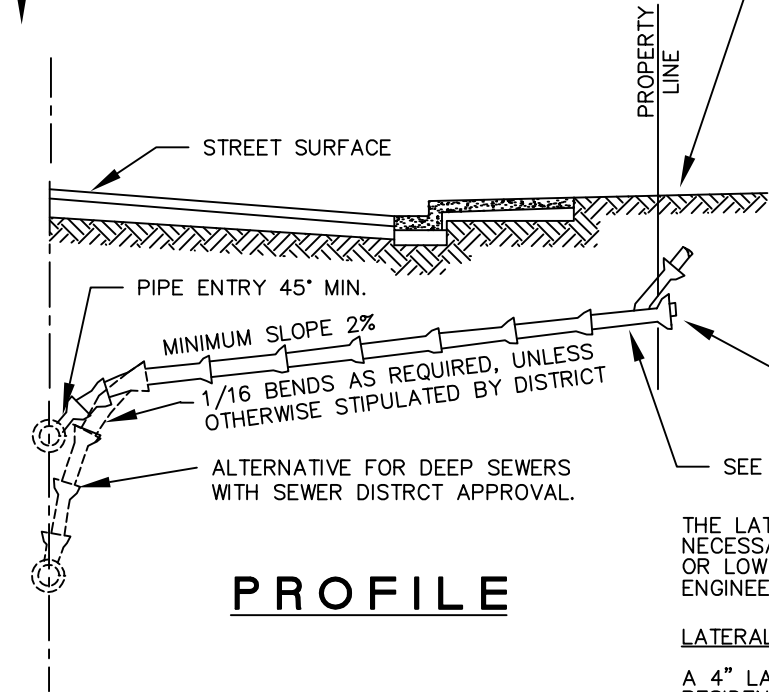

NOTE: (1) SEE DETAIL SHEET NO. C-3 FOR SAN MATEO COUNTY STANDARD CLEANOUT DETAIL.
(2) BEDDING AND BACKFILL MATERIAL SEE DETAILS C-6 (TYPE A OR B) OR C-7

THE LATERAL SHALL BE LOWER WHERE NECESSARY TO SERVE EXISTING PLUMBING OR LOW LOTS OR WHEN DIRECTED BY THE ENGINEER.

LATERAL SIZES

A 4" LATERAL CAN BE USED FOR A SINGLE FAMILY RESIDENCE OR A SFR WITH A SECOND UNIT. A MINIMUM 6" LATERAL SHALL BE USED FOR ALL OTHER DEVELOPMENTS.

METHOD OF ATTACHING LATERAL TO EXISTING SEWER WHERE NO WYE HAS BEEN PROVIDED

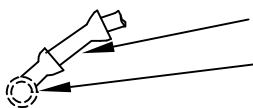

1. EXISTING MAIN \leq 8": FOR MEANS BY WHICH CONNECTION IS TO BE MADE TO MAIN LINE SEE DETAIL C-8.
2. EXISTING MAIN 10"-18": CONNECTION BY MEANS OF AN APPROVED SADDLE "TEE"
3. EXISTING MAIN $>$ 18": CONNECTION SHALL BE AT A MANHOLE UNLESS OTHERWISE APPROVED BY THE SEWER DISTRICT.

SEWER LATERAL DETAIL

**COUNTY OF SAN MATEO DEPARTMENT
OF**

PUBLIC WORKS

.....
REDWOOD CITY
CALIFORNIA

DRAWN BY: A.Z.
CHECKED BY: K.L.
APPROVED BY: A.M.S.

SCALE: NONE
DATE: 2-2022
REVISED: 2-2022

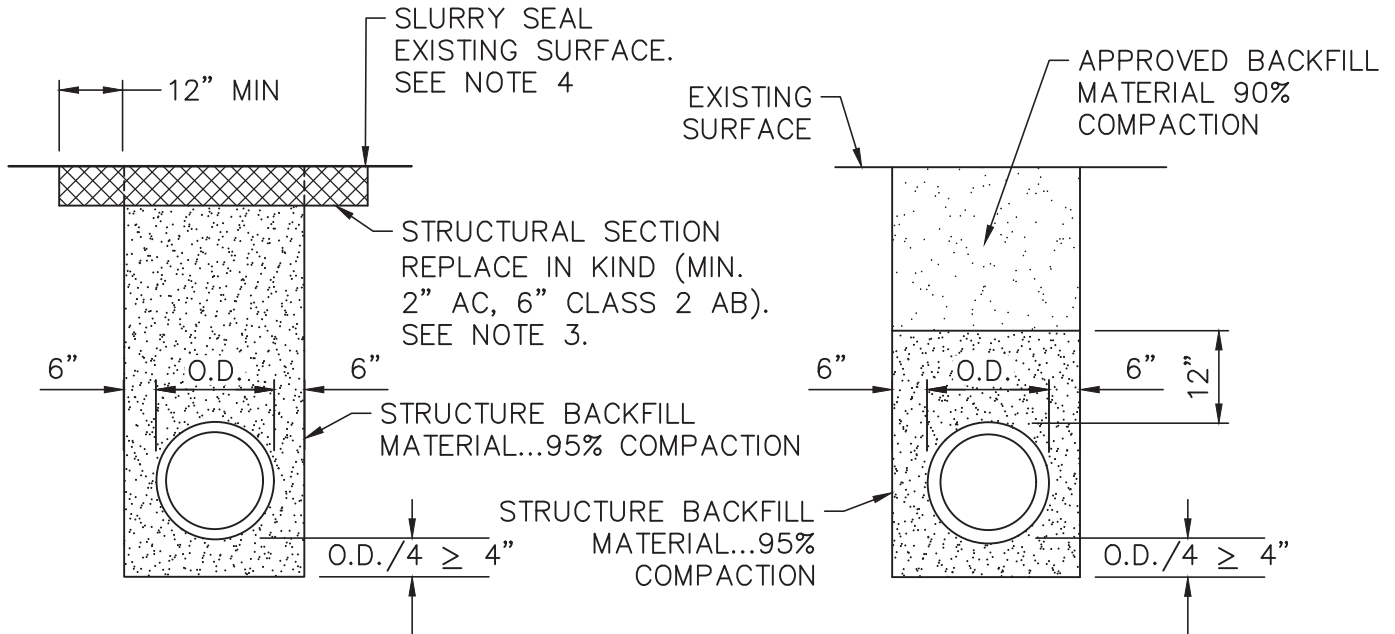

TYPE A (IN ROADWAY)

TYPE B (OUTSIDE ROADWAY)

NOTES:

1. STRUCTURE BACKFILL MATERIAL....MATERIAL WITH SAND EQUIVALENT NOT LESS THAN 20 AND SIEVE GRADATION BY WEIGHT AS FOLLOWS:

<u>SIEVE SIZE</u>	<u>% PASSING SIEVE</u>
3"	100
No. 4	35-100
No. 200	20-100

2. BACKFILL MATERIAL.... MATERIAL FROM EXCAVATION, FREE FROM STONES OR LUMPS EXCEEDING 3 INCHES GREATEST DIMENSION, ORGANIC MATTER, OR OTHER UNSATISFACTORY MATERIAL.
3. ON TRENCHES THAT PARALLEL THE ROAD AND ARE WITHIN EXISTING BICYCLE LANES, THE WIDTH OF THE STRUCTURAL SECTION SHALL BE GREATER THAN OR EQUAL TO THE WIDTH OF THE EXISTING BICYCLE LANE, WHICHEVER IS WIDER. PAVING JOINTS WITHIN BICYCLE LANE ARE NOT ALLOWED.
4. FULL WIDTH SLURRY SHALL BE APPLIED TO THE FINISH SURFACE FROM EDGE OF PAVEMENT TO EDGE OF PAVEMENT WHEN THERE IS A MAIN OR LATERAL LINE INSTALLATION THAT IS GREATER THAN 100 FEET IN TOTAL LENGTH. SLURRY SEAL SHALL COMPLY WITH CALTRANS STANDARD SPECIFICATIONS. SPREAD RATE TO BE 17 LBS/SY (±1).

**STANDARD TRENCH BACKFILL AND BEDDING DETAIL
FOR VITRIFIED CLAY AND DUCTILE IRON SEWER PIPE**

**COUNTY OF SAN MATEO DEPARTMENT
OF**

PUBLIC WORKS

.....
REDWOOD CITY
CALIFORNIA

DRAWN BY: A.Z.
CHECKED BY: K.L.
APPROVED BY: A.M.S.

SCALE: NONE
DATE: 2-2022
REVISED: 2-2022

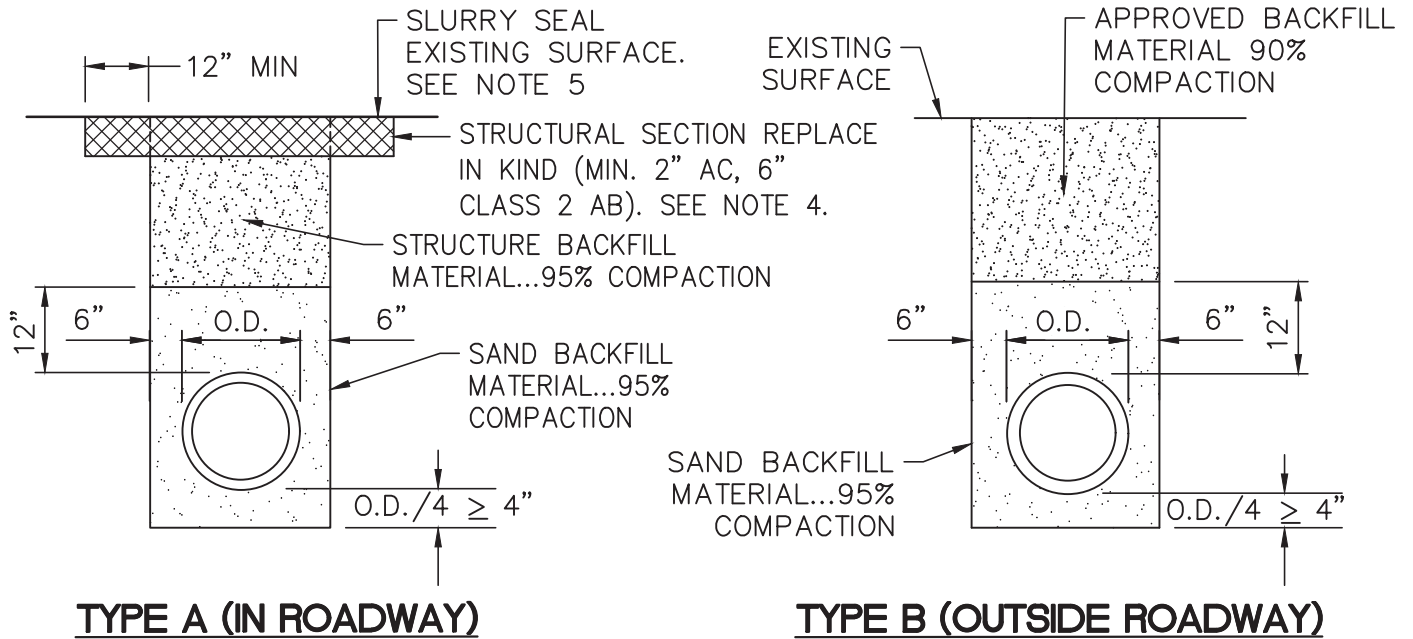

NOTES:

- SAND...MATERIAL FREE FROM ORGANIC MATTER AND CLAY WITH A SIEVE GRADATION BY WEIGHT AS FOLLOWS:

SIEVE SIZE	% PASSING SIEVE
No. 4	100
No. 200	0-5
- STRUCTURE BACKFILL MATERIAL...MATERIAL WITH SAND EQUIVALENT NOT LESS THAN 20 AND SIEVE GRADATION BY WEIGHT AS FOLLOWS:

SIEVE SIZE	% PASSING SIEVE
3"	100
No. 4	35-100
No. 200	20-100
- BACKFILL MATERIAL.... MATERIAL FROM EXCAVATION, FREE FROM STONES OR LUMPS EXCEEDING 3 INCHES GREATEST DIMENSION, ORGANIC MATTER, OR OTHER UNSATISFACTORY MATERIAL.
- ON TRENCHES THAT PARALLEL THE ROAD AND ARE WITHIN EXISTING BICYCLE LANES, THE WIDTH OF THE STRUCTURAL SECTION SHALL BE GREATER THAN OR EQUAL TO THE WIDTH OF THE EXISTING BICYCLE LANE. PAVING JOINTS WITHIN BICYCLE LANE ARE NOT ALLOWED.
- FULL WIDTH SLURRY SHALL BE APPLIED TO THE FINISH SURFACE FROM EDGE OF PAVEMENT TO EDGE OF PAVEMENT WHEN THERE IS A MAIN OR LATERAL LINE INSTALLATION THAT IS GREATER THAN 100 FEET IN TOTAL LENGTH. SLURRY SEAL SHALL COMPLY WITH CALTRANS STANDARD SPECIFICATIONS. SPREAD RATE TO BE 17 LBS/SY (±1).

**STANDARD TRENCH BACKFILL AND BEDDING DETAIL
FOR PVC SEWER PIPE**

SAN MATEO COUNTY DEPARTMENT
OF
PUBLIC WORKS

DRAWN BY: N.M.A.
CHECK BY: R.O.
APPROVED BY: N.R.C.

SCALE: NONE
DATE: 6/95
REVISED: _____

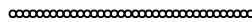

REDWOOD CITY
CALIFORNIA

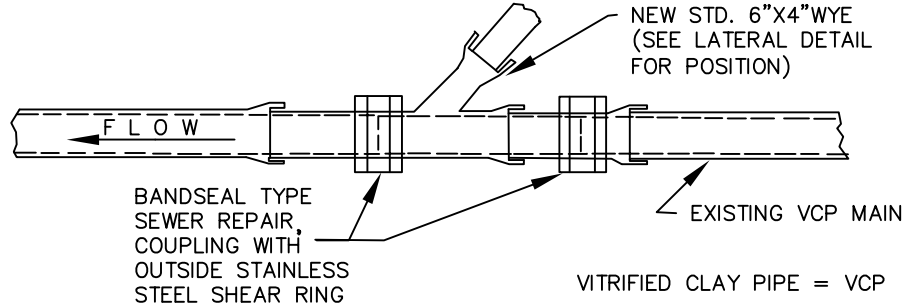

NOTE: (1) THE NEWLY INSTALLED WYE SHALL BE OF THE SAME MATERIAL AS THE EXISTING MAIN.

PLAN
VITRIFIED CLAY

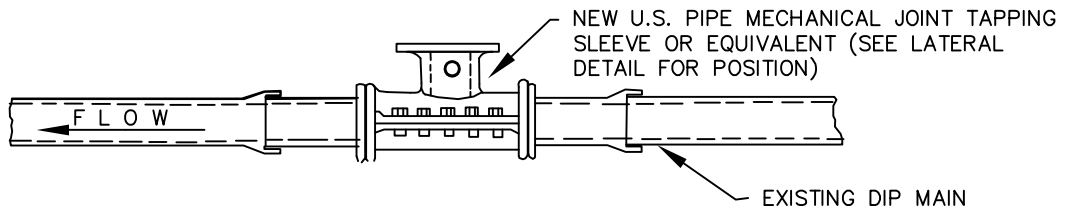

NOTES: HORIZONTAL PIPE ENTRY ANGLE WILL BE 90°, INSTEAD OF 45°
(SEE LATERAL DETAIL, PLAN VIEW)

VERTICAL PIPE ENTRY ANGLE SHALL BE 45° MINIMUM (SEE LATERAL DETAIL PROFILE VIEW)

PLAN
DUCTILE IRON PIPE

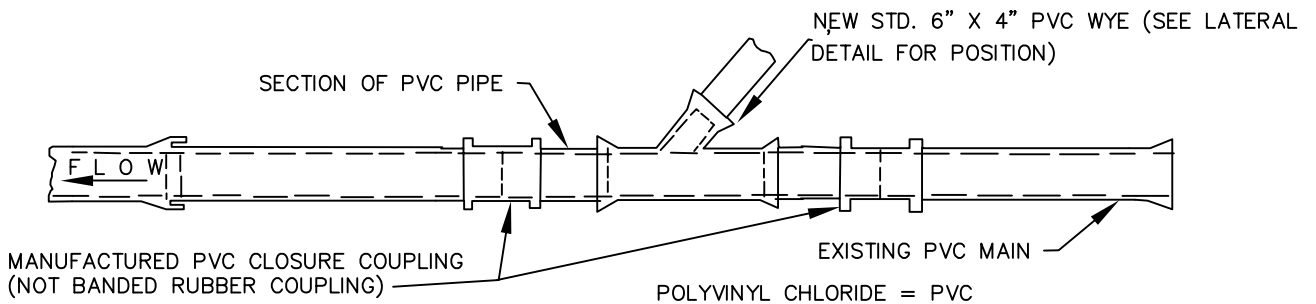

NOTE: ALL PVC, PIPE AND FITTINGS SHALL BE SDR 35 35 AND SHALL HAVE RUBBER GASKETED JOINTS.
SOLVENT WELDED JOINTS SHALL NOT BE ALLOWED.

PLAN
POLYVINYL CHLORIDE PIPE

LATERAL CONNECTION INSTALLATION DETAIL ON EXISTING PIPE

NOTE: LATERAL CONNECTION INSTALLATION ON NEWLY INSTALLED PIPE WILL BE AS DIRECTED
BY THE DEPARTMENT OF PUBLIC WORKS.

SAN MATEO COUNTY DEPARTMENT
OF
PUBLIC WORKS
.....
REDWOOD CITY
CALIFORNIA

DRAWN BY: N.M.A.
CHECK BY: R.O.
APPROVED BY: N.R.C.

SCALE: NONE
DATE: 6/95
REVISED: _____

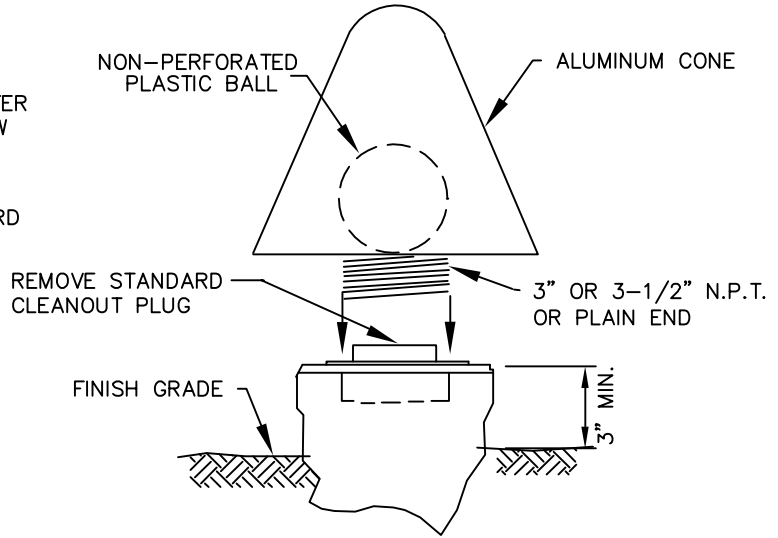
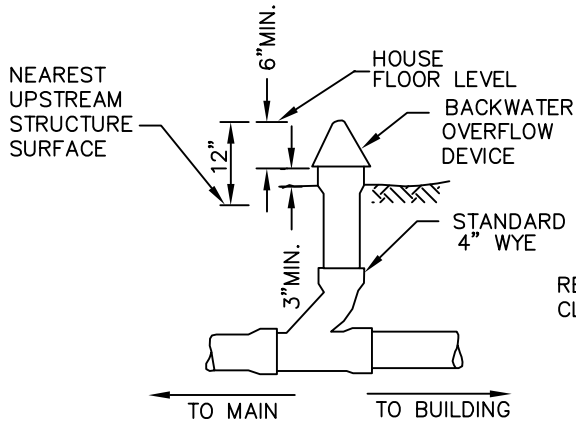

OVERFLOW DEVICE

NOTE: LOCATION OF DEVICE TO APPROVAL OF DISTRICT AND BUILDING DEPARTMENT PRIOR TO INSTALLATION

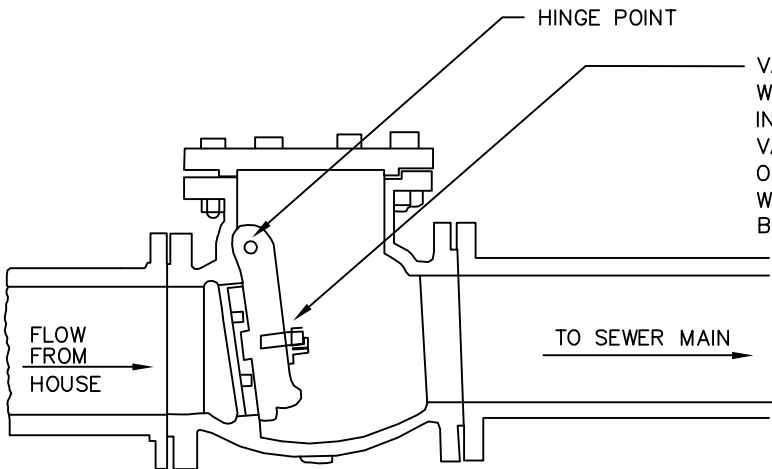

VALVE OPENS TO ALLOW WASTE WATER TO FLOW INTO SEWER MAIN; VALVE CLOSES BY ITS OWN WEIGHT TO PREVENT WASTEWATER FROM FLOWING BACK TO HOUSE LATERAL.

NOTE: LOCATION OF DEVICE TO APPROVAL OF DISTRICT AND BUILDING DEPARTMENT PRIOR TO INSTALLATION

BACKFLOW DEVICE

OVERFLOW AND BACKFLOW DEVICE DETAIL

SAN MATEO COUNTY DEPARTMENT
OF
PUBLIC WORKS
.....
REDWOOD CITY
CALIFORNIA

DRAWN BY: M.L.
CHECK BY: R.O.
APPROVED BY: N.R.C.

SCALE: NONE
DATE: 6/95
REVISED:

NOTICE:

CALL SANITARY DISTRICT (363-4765 OR 363-4100) BEFORE MAKING ANY SEWER REPAIRS. ALL REPAIRS MUST BE DONE IN THE PRESENCE OF A DISTRICT INSPECTOR.

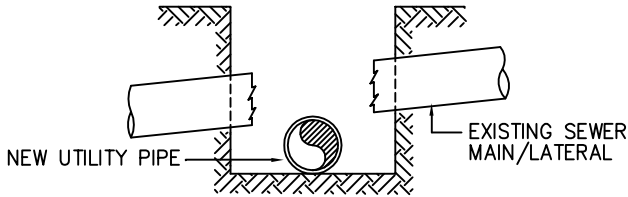

SIMPLE SEWER MAIN/LATERAL BREAK
(NO CONFLICT IN GRADE)

BREAK

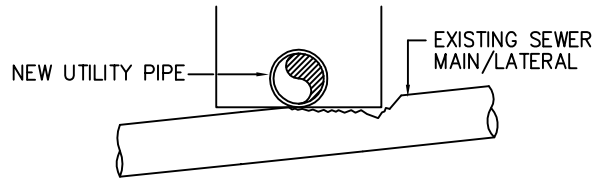

SIMPLE SEWER MAIN/LATERAL BREAK
(NO CONFLICT IN GRADE)

BREAK

BACKFILL MATERIAL FILL ENTIRE EXCAVATION OUTSIDE TRENCH AREA MIN. 18" EACH SIDE OF SEWER LINE

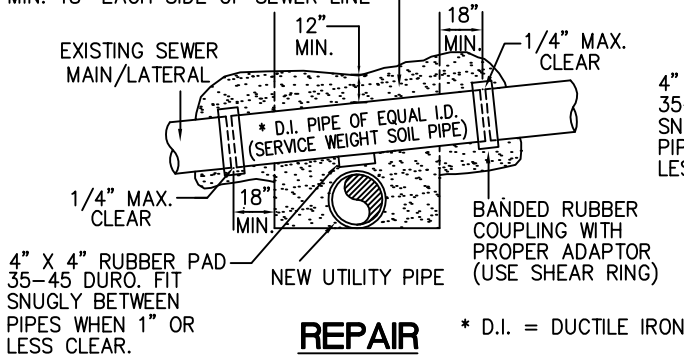

REPAIR

* D.I. = DUCTILE IRON

BACKFILL MATERIAL FILL ENTIRE EXCAVATION OUTSIDE TRENCH AREA MIN. 18" EACH SIDE OF SEWER LINE

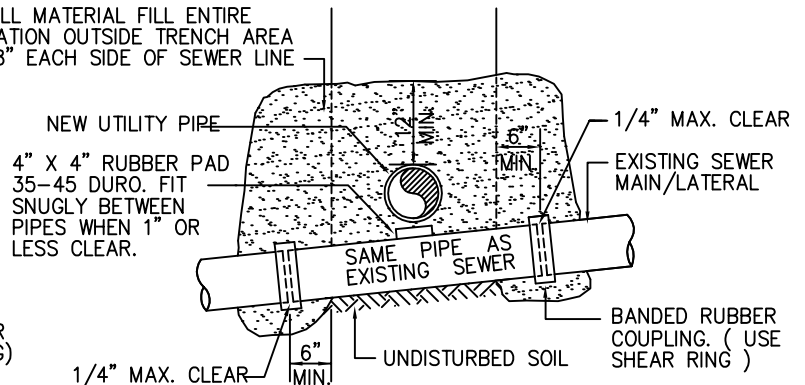

REPAIR

PROCEDURE:

1. NOTIFY SANITARY DISTRICT (363-4765 OR 363-4100)
2. TRIM SEWER PIPE TO A CLEAN CUT UNDATED END, A MINIMUM OF 18" INTO TRENCH WALL. CUT PIECE OF NEW DUCTILE IRON PIPE (D.I.P.) OF EQUAL DIAMETER TO FIT SPACE BETWEEN TRIMMED ENDS WITH A MAXIMUM CLEARANCE OF 1/4 INCH AT EACH END. ALIGN PIPES AT UPSTREAM END AND SLIDE COUPLING DOWNSTREAM, CENTERING IT OVER THE JOINT, TIGHTEN COUPLING BANDS. WHEN O.D. OF PIPES ARE WITHIN 1" OF EACH OTHER, THERE SHALL BE A 4"X4" PAD OF 35-45 DUROMETER RUBBER PLACED SNUGLY BETWEEN THE PIPES.
3. CONCRETE ENCASEMENT SHALL BE REQUIRED IN THE EVENT THE ADJACENT SOIL IS DISTURBED. LIMITS SHALL BE DETERMINED BY THE DISTRICT.

PROCEDURE:

1. NOTIFY SANITARY DISTRICT (363-4765 OR 363-4100)
2. REPAIR SHALL BE MADE AS SHOWN ABOVE WHEN CLEARANCE BETWEEN SEWER PIPE AND UTILITY PIPE IS 6" OR MORE, REPAIR MAY BE MADE WITH THE SAME TYPE OF PIPE AS THE EXISTING SEWER. WHEN O.D. OF PIPES ARE WITHIN 1" OF EACH OTHER, THERE SHALL BE A 4" X 4" PAD OF 35-45 DUROMETER RUBBER PLACED SNUGLY BETWEEN THE PIPES.
3. IF EXISTING SEWER PIPE IS PVC OR ABS, USE MANUFACTURED COUPLINGS AND NOT BANDED RUBBER COUPLINGS.
4. CONCRETE ENCASEMENT SHALL BE REQUIRED IN THE EVENT THE ADJACENT SOIL IS DISTURBED. LIMITS SHALL BE DETERMINED BY THE DISTRICT.

STANDARD DRAWING
VITRIFIED CLAY AND DUCTILE IRON SEWER PIPE
PIPE CROSSING REPAIR

SAN MATEO COUNTY DEPARTMENT
OF
PUBLIC WORKS
.....
REDWOOD CITY
CALIFORNIA

DRAWN BY: M.L.
CHECK BY: R.O.
APPROVED BY: N.R.C.

SCALE: NONE
DATE: 6/95
REVISED:

NOTICE:

CALL SANITARY DISTRICT (363-4765 OR 363-4100) BEFORE MAKING ANY SEWER REPAIRS. ALL REPAIRS MUST BE DONE IN THE PRESENCE OF A DISTRICT INSPECTOR.

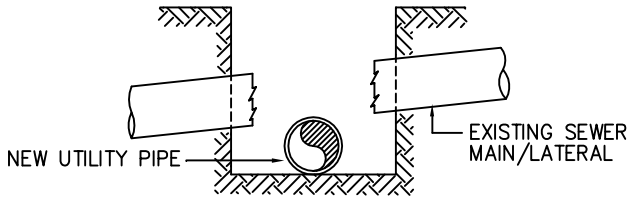

SIMPLE SEWER MAIN/LATERAL BREAK
(NO CONFLICT IN GRADE)

BREAK

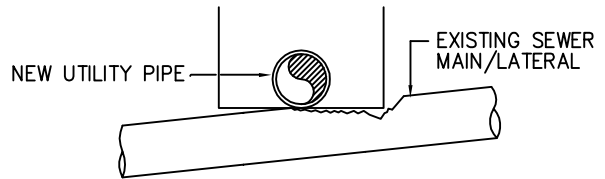

SIMPLE SEWER MAIN/LATERAL BREAK
(NO CONFLICT IN GRADE)

BREAK

BACKFILL MATERIAL (SEE NOTE 1), FILL ENTIRE EXCAVATION OUTSIDE TRENCH AREA MIN. 18" EACH SIDE OF SEWER LINE

BACKFILL MATERIAL (SEE NOTE 1), FILL ENTIRE EXCAVATION OUTSIDE TRENCH AREA MIN. 18" EACH SIDE OF SEWER LINE

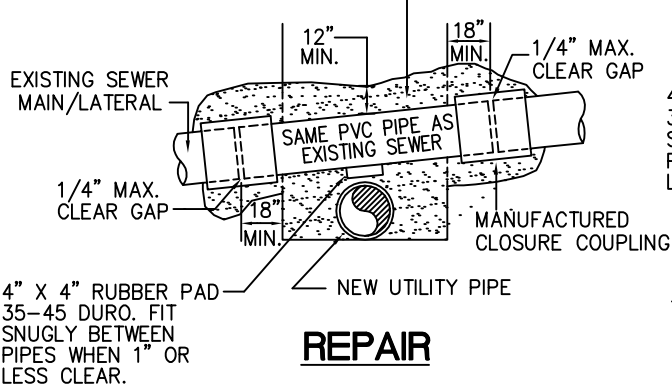

REPAIR

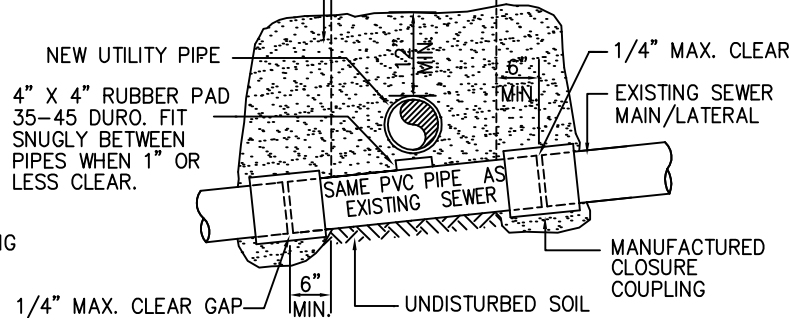

REPAIR

- NOTES:
1. BACKFILL MATERIAL SHALL BE SAND AS SPECIFIED IN STANDARD TRENCH BACKFILL AND BEDDING DETAIL FOR P.V.C. SEWER PIPE (C-7) OR OTHER MATERIAL APPROVED EQUAL BY THE SEWER DIVISION.
 2. THE USE OF BANDED RUBBER COUPLINGS IS PROHIBITED.

PROCEDURE:

PROCEDURE:

1. NOTIFY SANITARY DISTRICT (363-4765 OR 363-4100)
2. TRIM SEWER MAIN/LATERAL TO A CLEAN-CUT, UNDAMAGED END, A MINIMUM OF 18" INTO TRENCH WALL. INSTALL NEW PVC PIPE WITH MANUFACTURED CLOSURE COUPLINGS (IN ACCORDANCE WITH MANUFACTURER'S INSTRUCTIONS).
3. WHEN OUTSIDE DIAMETER OF THE CROSSING PIPES ARE WITHIN 1" OF EACH OTHER, THERE SHALL BE A 4" X 4" PAD OF 35-45 DUROMETER RUBBER PLACED SNUGLY BETWEEN THE PIPES.

1. NOTIFY SANITARY DISTRICT (363-4765 OR 363-4100)
2. WHEN O.D. OF PIPES ARE WITHIN 1" OF EACH OTHER, THERE SHALL BE A 4" X 4" PAD OF 35-45 DUROMETER RUBBER PLACED SNUGLY BETWEEN THE PIPES.

STANDARD DRAWING
POLYVINYL CHLORIDE (PVC) SEWER PIPE
PIPE CROSSING REPAIR

SAN MATEO COUNTY DEPARTMENT
OF

DRAWN BY: N.M.A.
CHECK BY: R.O.
APPROVED BY: N.R.C.

PUBLIC WORKS
.....
REDWOOD CITY
CALIFORNIA

SCALE: NONE
DATE: 6/95
REVISED: _____

**SAN MATEO COUNTY SEWER AND SANITATION DISTRICTS
STANDARD SPECIFICATIONS**

GENERAL NOTES

1. ALL REFERENCES TO "DISTRICT" IN THESE GENERAL NOTES SHALL MEAN THE APPROPRIATE COUNTY SEWER OR SANITATION DISTRICT.
2. THE APPROVAL OF THESE PLANS BY THE DISTRICT SHALL BE INTERPRETED TO MEAN THAT THE SANITARY SEWER DESIGN SHOWN ON THESE PLANS MEETS THE DISTRICT'S STANDARDS. THE DISTRICT'S APPROVAL IN NO WAY GUARANTEES ANY OTHER ASPECT OF THIS PLAN OR ITS ACCURACY RELATIVE TO ACTUAL FIELD CONDITIONS.
3. THE CONTRACTOR SHALL CONTACT THE DISTRICT AT 363-4765 OR 363-4100 TWO (2) WORKING DAYS IN ADVANCE OF BEGINNING ANY SANITARY SEWER WORK. THE CONTRACTOR SHALL THEREAFTER KEEP THE INSPECTOR FOR THE DISTRICT INFORMED OF HIS SCHEDULE FOR SANITARY SEWER WORK.
4. ALL SANITARY SEWER WORK CONSTRUCTED WITHOUT INSPECTION BY THE DISTRICT SHALL BE REMOVED AND RECONSTRUCTED WITH INSPECTION.
5. THE CONTRACTOR SHALL CONTACT UNDERGROUND SERVICE ALERT FORTY-EIGHT (48) HOURS IN ADVANCE OF BEGINNING ANY WORK.
6. THE CONTRACTOR SHALL FIELD VERIFY THE LOCATION OF ALL UTILITIES BEFORE BEGINNING ANY EXCAVATING.
7. THE CONTRACTOR SHALL OBTAIN ANY AND ALL PERMITS REQUIRED BY THE COUNTY OR CITY BEFORE BEGINNING ANY SANITARY SEWER WORK.
8. UPON THE COMPLETION OF CONSTRUCTION A COMPLETE SET OF REPRODUCIBLE "AS-CONSTRUCTED" PLANS SHALL BE PROVIDED TO THE DISTRICT.
9. SANITARY SEWER SERVICE SHALL BE MAINTAINED AT ALL TIMES. THE CONTRACTOR SHALL USE WHATEVER MEANS ARE NECESSARY (E.G. PUMPS, ETC.) TO MAINTAIN THIS SERVICE DURING CONSTRUCTION.
10. PRIOR TO COMMENCING ANY SANITARY SEWER WORK IN OFF-SITE EASEMENTS THE CONTRACTOR SHALL PROVIDE THE DISTRICT WITH ADEQUATE EVIDENCE THAT ALL AFFECTED PROPERTY OWNERS (AND TENANTS WHERE APPLICABLE) WERE NOTIFIED WELL IN ADVANCE OF THE DATE WORK IN THESE EASEMENTS WAS TO BEGIN AND THAT THEY HAVE UPDATED THAT NOTICE IN A TIMELY MANNER WHEN THOSE DATES HAVE CHANGED.

SAN MATEO COUNTY DEPARTMENT
OF

DRAWN BY: N.M.A.
CHECK BY: R.O.
APPROVED BY: N.R.C.

PUBLIC WORKS
.....
REDWOOD CITY
CALIFORNIA

SCALE: NONE
DATE: 6/95
REVISED: 4/97

**SAN MATEO COUNTY SEWER AND SANITATION DISTRICTS
STANDARD SPECIFICATIONS**

PIPE AND FITTINGS

POLYVINYL CHLORIDE PIPE (PVC)

1. ALL PIPE AND FITTINGS SHALL CONFORM TO ASTM SPECIFICATIONS D3034, SDR 35.
2. ALL JOINTS SHALL BE A BELL AND SPIGOT ASSEMBLY WITH ELASTOMERIC SEALING GASKETS. SEALING GASKETS SHALL MEET THE REQUIREMENTS OF ASTM SPECIFICATION D1869. SOLVENT CEMENT JOINTS ARE NOT PERMITTED.
3. ALL PIPE ENTERING OR LEAVING A CONCRETE STRUCTURE SHALL HAVE A RUBBER WATERSTOP GASKET ATTACHED TO IT. THE WATERSTOP GASKET SHALL CONFORM TO THE PIPE MANUFACTURER'S SPECIFICATIONS. THE WATERSTOP GASKET SHALL BE SEATED FIRMLY AROUND THE PIPE EXTERIOR AND BE CAST INTO THE CONCRETE STRUCTURE.
4. ALL PIPE JOINTS SHALL BE MADE USING MANUFACTURED PVC COUPLINGS. BAND TYPE COMPRESSION COUPLINGS ARE NOT PERMITTED.

DUCTILE IRON PIPE (DIP)

1. ALL PIPE SHALL BE THICKNESS CLASS 50 (FOUR INCH PIPE SHALL BE THICKNESS CLASS 51) IN ACCORDANCE WITH ANSI SPECIFICATIONS A21.51. FITTINGS SHALL BE IN ACCORDANCE WITH ANSI SPECIFICATION A21.10.
2. JOINTS SHALL BE PUSH-ON TYPE OR MECHANICAL JOINT TYPE IN ACCORDANCE WITH ANSI SPECIFICATION A21.11. RUBBER GASKETS FOR PUSH-ON JOINTS SHALL BE IN ACCORDANCE WITH ANSI SPECIFICATIONS HEREIN.
3. PIPE AND FITTINGS SHALL HAVE A BITUMINOUS COATING OUTSIDE IN ACCORDANCE WITH ASTM SPECIFICATION A746-86, UNLESS OTHERWISE SPECIFIED HEREIN.
4. PIPE AND FITTINGS SHALL HAVE A 1/16" (ONE-SIXTEENTH INCH) CEMENT-MORTAR LINING WITH AN ASPHALTIC SEAL COAT.

VITRIFIED CLAY PIPE (VCP)

1. PIPE AND FITTINGS SHALL BE EXTRA STRENGTH, UNGLAZED, BELL AND SPIGOT, CONFORMING TO THE LATEST REVISION OF ASTM SPECIFICATION C700.
2. JOINTS SHALL BE A BELL AND SPIGOT ASSEMBLY WITH FACTORY INSTALLED FLEXIBLE COMPRESSION TYPE GASKETS MADE OF PLASTICIZED POLYVINYL OR POLYURETHANE CONFORMING TO THE LATEST REVISION OF ASTM SPECIFICATIONS C425. BAND TYPE COUPLINGS ARE NOT ALLOW.

SAN MATEO COUNTY DEPARTMENT
OF

DRAWN BY: N.M.A.
CHECK BY: R.O.
APPROVED BY: N.R.C.

PUBLIC WORKS
.....
REDWOOD CITY
CALIFORNIA

SCALE: NONE
DATE: 6/95
REVISED: _____

**SAN MATEO COUNTY SEWER AND SANITATION DISTRICTS
STANDARD SPECIFICATIONS
TESTING REQUIREMENTS**

1. ALL REFERENCES TO "DISTRICT" IN THESE TESTING REQUIREMENTS SHALL MEAN THE APPROPRIATE COUNTY SEWER OR SANITATION DISTRICT.
2. ALL REQUIRED CLEANING AND TESTING OF SANITARY SEWER MAINS AND LATERALS SHALL BE PERFORMED IN THE PRESENCE OF A REPRESENTATIVE OF THE DISTRICT.
3. ALL SANITARY SEWER MAINS BEING CONSTRUCTED SHALL BE CLEANED BY MEANS OF A HIGH SPEED JET RODDER PRIOR TO TESTING. VCP AND DIP SHALL BE TESTED FOR OBSTRUCTION BY BALL ROLLING.
4. ALL SANITARY SEWER MAINS BEING CONSTRUCTED SHALL PASS A LOW PRESSURE AIR TEST. EACH SECTION OF MAIN SHALL BE TESTED BETWEEN SUCCESSIVE MANHOLES. THE LOW PRESSURE AIR TEST SHALL BE CONDUCTED IN THE FOLLOWING MANNER.

A COMPRESSED AIR SUPPLY SHALL BE ATTACHED TO AN AIR FITTING ON THE MAIN AND THE AIR PRESSURE WITHIN THE LINE INCREASED TO FOUR (4) POUNDS PER SQUARE INCH. (PSI). AFTER THE AIR SUPPLY IS SECURELY TURNED OFF OR DISCONNECTED, THERE SHALL BE A TWO (2) MINUTE WAITING PERIOD BEFORE THE ACTUAL TEST PERIOD BEGINS TO ALLOW STABILIZATION OF AIR WITHIN THE MAIN.

IN NO CASE SHALL THE AIR PRESSURE WITHIN THE LINE BE LESS THAN 3.5 PSI AT THE BEGINNING OF THE TEST PERIOD. REFER TO THE CHART WHICH FOLLOWS FOR THE LENGTH OF THE TEST PERIOD. THE MINIMUM LENGTH OF TEST IS TWO (2) MINUTES). THE ALLOWABLE AIR PRESSURE LOSS DURING THE TEST PERIOD SHALL BE 1.0 PSI. A WRITTEN RECORD OF THE TEST SHALL BE SUBMITTED TO THE DISTRICT BY THE CONTRACTOR.

NOMINAL PIPE SIZE (inches)	LENGTH OF LINE (feet)	LENGTH OF TEST (minutes)
4	ALL	2
6	0 - 300	2
6	300 - 370	2 1/2
6	370 AND GREATER	3
8	0 - 170	2
8	170 - 210	2 1/2
8	210 - 250	3
8	250 - 290	3 1/2
8	290 AND GREATER	3 3/4
10	0 - 110	2
10	110 - 165	3
10	165 - 215	4
10	215 AND GREATER	4 3/4

SAN MATEO COUNTY DEPARTMENT
OF

DRAWN BY: N.M.A.
CHECK BY: R.O.
APPROVED BY: N.R.C.

PUBLIC WORKS
.....
REDWOOD CITY
CALIFORNIA

SCALE: NONE
DATE: 6/95
REVISED:

5. A TELEVISION INSPECTION SHALL BE MADE OF ALL SANITARY SEWER MAINS BEING CONSTRUCTED. IMMEDIATELY PRIOR TO TELEVISIONING THE SEWER, AN AMOUNT OF WATER ACCEPTABLE TO THE DISTRICT'S REPRESENTATIVE SHALL BE INTRODUCED INTO THE SEWER MAIN BEING INSPECTED.

A VIDEO TAPE IN VHS FORMAT AT SP, OR EQUIVALENT, SPEED SHALL BE MADE OF THE INSPECTION AND DELIVERED ALONG WITH A TYPED LOG OF THE INSPECTION TO THE DISTRICT (SAN MATEO COUNTY DEPARTMENT OF PUBLIC WORKS) FOR REVIEW AND ACCEPTANCE.

SUBMITTED VIDEO TAPES SHALL INCLUDE A CONTINUOUS ON-SCREEN DISPLAY WHICH CONTAINS, AS A MINIMUM, THE DATE OF THE FILMING, IDENTIFICATION OF THE LINE AND SEGMENT (REACH) OF THE LINE BEING VIEWED, AND A READOUT, IN FEET, SHOWING THE DISTANCE TO THE ENTRY POINT.

IF, IN THE OPINION OF THE DISTRICT, THE SUBMITTED VIDEO TAPES ARE OF POOR QUALITY, THE DISTRICT MAY REJECT THE VIDEO TAPES AND REQUIRE THE VIDEO INSPECTION TO BE REPEATED AND NEW VIDEO TAPES SUBMITTED TO THE DISTRICT FOR REVIEW AND ACCEPTANCE. ALL VIDEO TAPES SHALL BECOME THE PROPERTY OF THE DISTRICT.

6. DEFLECTION TESTING OF POLYVINYL CHLORIDE (PVC) SEWER MAINS SHALL BE PERFORMED AFTER THE PLACEMENT OF ALL TRENCH BACKFILL. PIPE DEFLECTION SHALL BE TESTED BY PULLING BY HAND A GO/NO-GO MANDREL THROUGH THE INSTALLED SECTIONS OF SEWER MAIN.

THE MANDREL USED SHALL HAVE A MINIMUM LENGTH EQUAL TO ITS DIAMETER. THE MANDREL SHALL BE CONSTRUCTED WITH A MINIMUM OF NINE (9) RIBS FABRICATED PARALLEL TO ITS LONGITUDINAL AXIS. BOTH THE DESIGN OF THE MANDREL AND THE FABRICATED MANDREL ITSELF SHALL BE INSPECTED AND APPROVED BY THE DISTRICT WELL IN ADVANCE OF THE DEFLECTION TEST.

THE MANDREL DIAMETER SHALL BE 95% OF THE PIPE'S AVERAGE INSIDE DIAMETER AS DEFINED BY ASTM SPECIFICATION D3034, AND AS DETAILED IN THE FOLLOWING TABLE:

NOMINAL PIPE SIZE (inches)	AVERAGE INSIDE DIAMETER (inches)	MINIMUM MANDREL DIAMETER (inches)
-------------------------------	----------------------------------------	-----------------------------------------

6	5.893	5.598
8	7.891	7.497
10	9.864	9.371

NOTE: AVERAGE INSIDE DIAMETER = AVERAGE OUTSIDE DIAMETER - 2(1.06)T; WHERE T = MINIMUM WALL THICKNESS AS DEFINED BY ASTM SPECIFICATION D3034.